

OPERATING MANUAL

RWS-30

Visibility Sensor

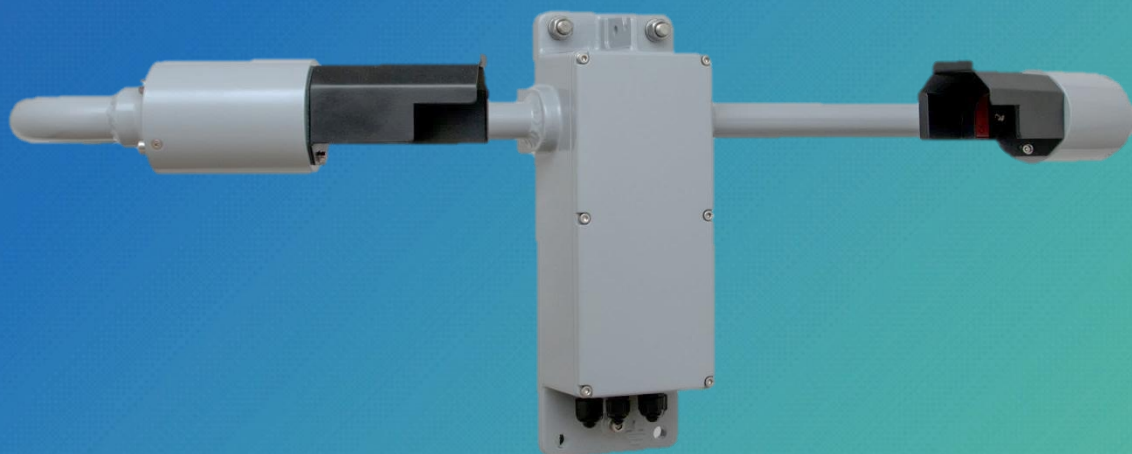

EN

108319.00B



[INTENTIONALLY BLANK]

Contents

General Information.....	5
1 UNPACKING THE SENSOR.....	8
2 INSTALLATION.....	9
2.1 Siting Considerations.....	9
2.2 Height Above Ground	10
2.3 Orientation of Sensor Head.....	10
2.4 Mounting the Sensor.....	11
2.5 Electrical Connections.....	12
2.6 Analogues & Relays (AR).....	21
3 SYSTEM INTEGRATION.....	22
3.1 Analogues & Relays.....	22
3.2 Serial Interface.....	23
4 ADVANCED SENSOR OPTIONS	25
4.1 Sensor Commands and Responses	25
4.2 Serial Communications Configuration	28
4.3 Analogues & Relays Configuration	36
4.4 Sensor Heater Options.....	40
4.5 Visibility Settings.....	42
4.6 Sensor Status	44
5 TEST MODE.....	45
5.1 Test Command.....	45
6 MAINTENANCE PROCEDURES	47
6.1 General Checks.....	47
6.2 Self-Test Codes.....	48
6.3 Baud Rate Recovery	50
7 CALIBRATION PROCEDURES	51
7.1 Calibration Plaque Identification.....	51
7.2 Calibration Check.....	52
7.3 Sensor Re-Calibration.....	56
8 VISIBILITY	58
8.1 Visibility Measurements.....	58
9 SENSOR SPECIFICATIONS.....	59
9.1 Visibility Measurement	59
9.2 Sensor Characteristics.....	60
9.3 Power Requirements	61

9.4 Environmental.....62

9.5 Maintenance.....62

9.6 Digital Communication Interface62

9.7 Analogue Outputs64

9.8 Relay Outputs64

9.9 Physical Properties.....65

10 INDEX66

General Information

The RWS-30 sensor uses IR light to measure visibility. The sensors contain self-test routines to ensure accurate and reliable operation. The RWS-30 has both serial and various analogue output options. Over years of development this sensor has been refined to provide a robust and cost-effective solution.

The sensors covered in this manual:

<u>Sensor Model</u>	<u>Capability</u>
RWS-30	Visibility Obstruction to Vision

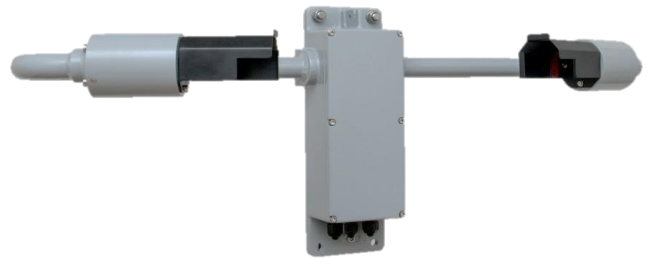

Features of the RWS-30 Sensor:

- **Wide Range of Data Interfaces:**
 - RS232, RS422, RS485
 - 0-10VDC,
 - 0-20mA, 4-20mA
 - Optional Relays
- **Easy Installation**
- **Compact Design**
- **Simple Field Calibration**
- **Comprehensive Self-Test and Diagnostics**
- **Optional Heating for Extreme Environments.**



Thank you for choosing Senseca as your supplier of visibility and present weather sensors.

A great deal of time has been invested at Senseca to offer the best combination of sensor performance and value and more than four decades of experience and knowledge have been incorporated into the RWS series. We are confident that they will provide you with many years of accurate operation.

Two-year warranty

The RWS-30 comes with a two-year limited warranty against defective materials and workmanship. If you have any questions about the warranty, please contact Senseca.

CE Certification - Safety

All Senseca's RWS sensors comply with the requirements for CE marking. Once installed, it is the user's responsibility to ensure that all connections made to the sensor comply with all Local and National safety requirements.

Customer Satisfaction

At Senseca we set our standards high and only your complete satisfaction is acceptable to us. If you believe your experience has not met these standards we would be grateful if you would contact us so we can rectify any issues you may have (equally, if you have any positive experiences you would like to share).

After Sales Support

Senseca offers support by telephone and email for the lifetime of these sensors, even if there has been a change of ownership, so please get in touch if you require help. Similarly, if you have any questions about your new equipment we are only a mouse-click or telephone call away. Our contact details are given below.

For your convenience our contact details are also on the label fixed to your sensor.

Contacting Senseca

If you would like technical assistance, advice or you have any queries regarding the operation of the sensor please do not hesitate to contact us.

For enquiries and technical support:

Contact us by telephone on: + 44 (0)1275 847787

Contact us by e-mail at: info.bristol@senseca.com

In order to help us to assist you please be sure to include the following information:

- Model of equipment
- Serial number of equipment
- Nature of defect
- Your full name, address and contact details

If possible, include the following:

- Relevant application details and data output
- Response to R? command (see section 4.6)
- Pictures of device/defect

1 UNPACKING THE SENSOR

Check the package contents match the below:

Item List:

- RWS Sensor
- U-bolts for pole mounting
- Documentation Pack including User Manual
- Other Optional Items

Optional components you may have ordered:

Calibration Kit

The calibration kit in a protective carrying case, containing: a calibration screen, a mounting arm (referred to as the calibration reference plaque when assembled) and 3 grey foam plugs (see section 7, for application).

Power and Signal Cables

Power and signal (data) cables. The length must be specified at time of order. Note these are not supplied by default.

Test Kit

The test kit, which is similar to the calibration kit, enables the end user to perform confidence checks on the sensor outputs and any connected equipment based on a preset visibility threshold. The preset visibility is specified at the time of order.

2 INSTALLATION

It is recommended the user familiarises themselves with the features and operation by testing the sensors prior to installation. It is advised any configuration changes from the factory settings are made prior to installation. See section 4 for configuration options.

Please consider the following factors when installing the sensor:

- (1) Siting considerations.
- (2) Height of the sensor above ground.
- (3) Orientation of the sensor.
- (4) Mounting the sensor.

Each of these factors is covered in more detail below:

2.1 Siting Considerations

Pollutants – Care should be taken to ensure that the sensor is situated away from any possible sources of undesired pollutants (for example air-conditioning outlets, steam vents, car exhausts etc.). Particulates entering the sensor's sample volume may cause errors in the reported visibility measurements.

Reflected Light – Care should be taken to ensure that the sensor is situated away from any surfaces which could cause reflections of the IR illumination from the transmitter (for example walls, trees and people, etc.). Reflected IR illumination entering the sensor's optics will cause errors in the reported visibility measurements.

Air-flow – Care should be taken to ensure that the sensor is situated away from objects that disrupt the 'normal' flow of air to and through the sensor sampling volume (for example walls, trees and other equipment, etc.).

Traffic – Where possible the sensor should be mounted facing away from traffic to avoid spray contaminating the lenses. Note, orientation away from direct sunlight is of higher priority. The sensor should be mounted not less than 3 metres away from the road.

2.2 Height Above Ground

The optimum height at which to mount the sensor depends on the application. The visibility can vary over a short elevation change (e.g. radiation fog), therefore the sensor height should match that of desired application. The table below shows recommended heights.

Application	Typical height	Comment
Highway fog-warning systems	1.5 to 2 metres (4.9 to 6.6 feet)	Recommended height for the sensor sample volume is the average distance of a vehicle driver's eyes above the roadway.

Table 1 Sensor Height Above Ground

2.3 Orientation of Sensor Head

The orientation of the sensor heads should be such that the rising or setting sun does not appear in the field-of-view of the receiver lenses. When the sun directly enters the receiver, the sensor will report the maximum level of background illumination. The sensor is unable to operate if the sun directly enters the receiver and will report 10m visibility as a fail-safe.

The recommended orientation is shown in Figure 2-1. These instructions assume the sensor is located within the Northern hemisphere with the optimum position being with the receiver head pointing directly due North.

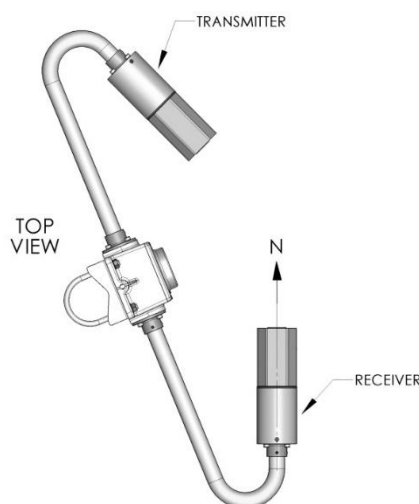

Figure 2-1 RWS-30 Orientation (Northern Hemisphere)

For sensors located in the Southern hemisphere, 180° should be added to the above directions.

2.4 Mounting the Sensor

On a pole

Two stainless steel U-bolts and saddles are provided for securing the sensor to the top of a mast, see Figure 2-2 U-Bolt Mounting Method~~Error! Reference source not found.~~. The two V-block saddles oppose the U-bolt, thus providing a secure grip on the mast. The sensor can be mounted on a tube with an outer diameter between 40 to 64 mm. For mast diameters outside this range the U-bolts provided will not be suitable.

The sensor head should be mounted near the very top so that the mast will not interfere more than necessary with the free flow of fog or precipitation through the sample volume.

The flat stainless-steel washers should be placed next to the powder coated surface of the mounting plate to prevent gouging by the lock washers as the nuts are tightened.

Figure 2-2 U-Bolt Mounting Method

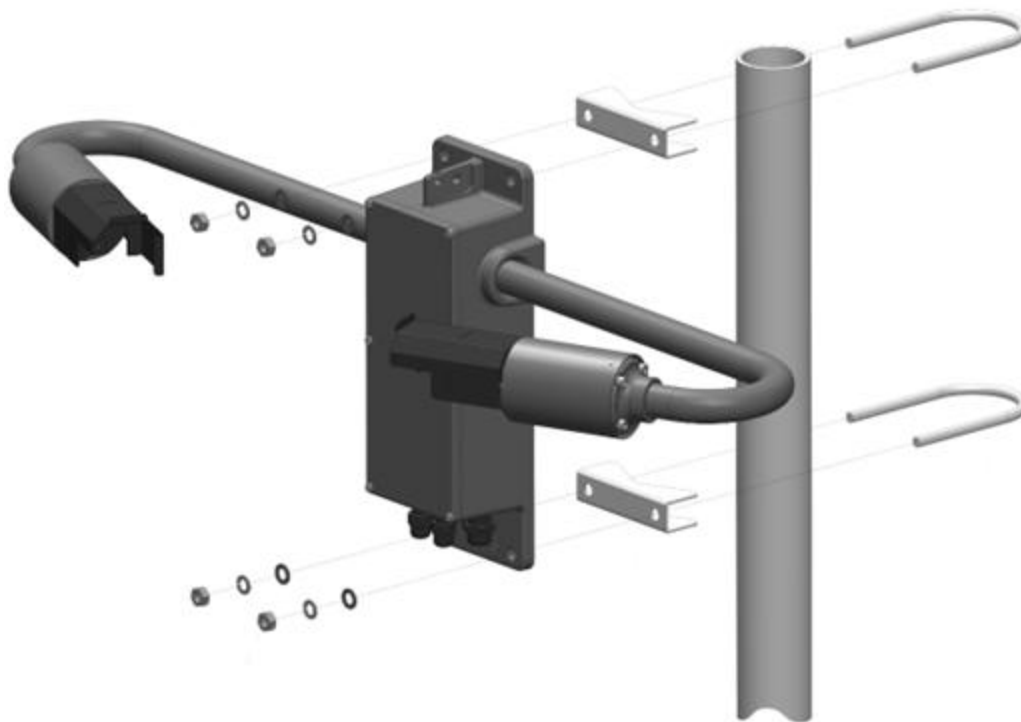

2.5 Electrical Connections



WARNING

ALL ELECTRICAL CONNECTIONS SHOULD BE COMPLETED PRIOR TO APPLYING POWER TO THE SENSOR
THE RWS SENSOR MUST BE SUITABLY EARTHED

2.5.1 Cables

Unless purchased as an option the sensor is not supplied with power and data cables. Power and data cable can be purchased separately from Senseca by the metre.

For the power we recommend the use of 20AWG/0.5mm² screened cable to ensure the current carrying capacity for sensors with heaters. For data cables we recommend screened, twisted pair cables. Both cables should be in a suitable outdoor UV and EMC resistant sheath. Only the screen of the power cable should be earthed at the sensor end. In the event a single cable is used for both power and data take the overall screen to earth.

The connectors accommodate 26AWG (0.13mm²) down to 16AWG (1.3mm²) wire. The user may optimise the cabling for their application but must do so at their own risk. Long cable runs may require planning for voltage drop purposes.



NOTE:

The RS232 configuration is suited to low to moderate electrical noise environments with moderate cable lengths and baud rates. For higher electrical noise environments with higher baud rates and longer cable lengths RS422 is recommended.



CAUTION:

In the event relays are being used to switch mains voltages, it will be necessary to use cables approved for mains use. A protective earth must be fitted to the sensor.

2.5.2 Cable Glands

By default, four cable glands are provided (see Figure 2-3):

- the 2 small cable glands are for cables between 3.5 to 7.00mm diameter
- the 2 larger glands are for cable between 4.5 to 10mm diameter

Any or all of these glands can be used.

Unused Glands

Any glands not in use should be sealed with the supplied sealing plugs to retain the integrity of the weatherproof housing.

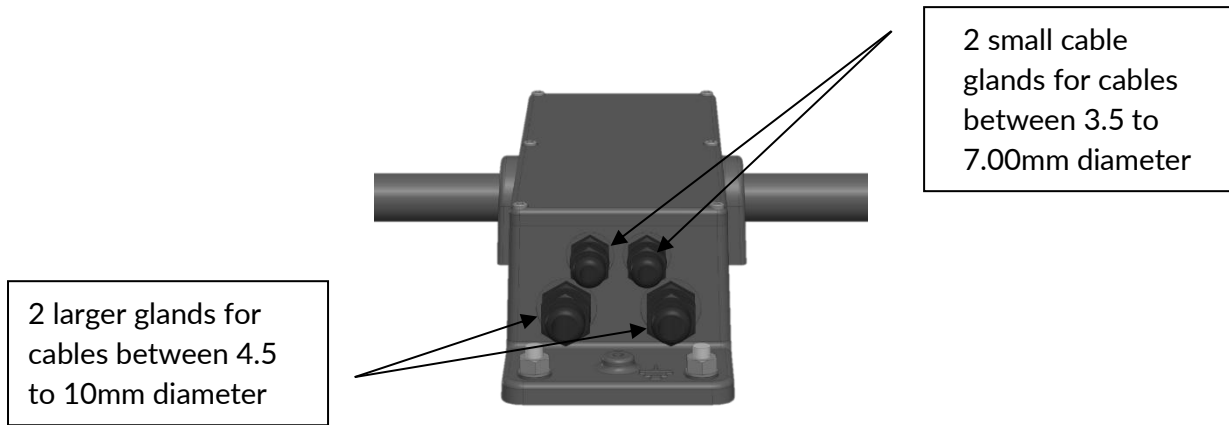

Figure 2-3 Cable Glands

2.5.3 Power and Data Connections

The power and signal cables are connected to the sensor using removable connectors along the bottom edge of the main circuit board adjacent to the cable glands.

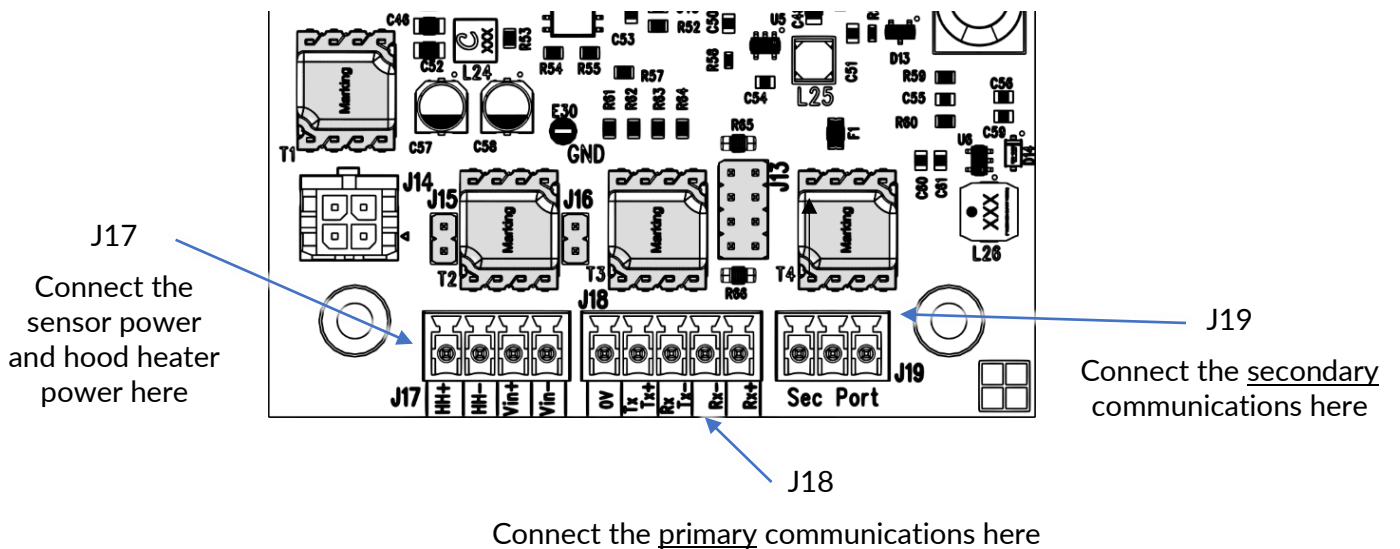

Figure 2-4 RWS Main Board – Power and Data Connections

2.5.3.1 Power supply

All RWS sensors require a sensor input voltage supply between 9 and 36V DC. Typical the sensor is powered by 24VDC and uses 3.5W. This will rise to 5W if the no-dew window heaters are in use. Heaters and optional accessories can increase the overall power consumption up to 30W. This can be supported by the optional Senseca power cable.

Mating Connector - Wurth 691361100004

Pin Number	Designation
J17 - 1 (HH+)	Hood Heater +ve
J17 - 2 (HH-)	Hood Heater -ve
J17 - 3 (Vin+)	Sensor Power +ve
J17 - 4 (Vin-)	Sensor Power -ve

Table 2 Power Supply Pinout

Connecting the Sensor Power

With the power removed from the supply cable, connect the positive lead to J17 Vin+ and the negative lead to J17 Vin-.

The negative lead is the internal signal 0V reference point. Care must be taken, particularly when long power leads are used, to ensure that this negative supply lead is at near ground potential. If it develops more than $\pm 10V$ DC with respect to ground, damage will be caused to the sensor.

Connecting the Hood Heaters

Hood Heaters by default are wired independently and isolated from the sensor power. These can be powered from a 24V AC/DC supply. The RWS-30 will draw 24W from this source.



Caution:

A higher hood heater voltage should not be used as the temperature of hoods will increase above acceptable levels.

For additional information on hood heaters see section 4.4.

Single Power Source – Hood Heater & Sensor DC

If using a 24VDC supply, it is possible to link the hood heater and sensor DC power locally on the board. This allows for a simpler installation whereby only two cable cores are wired to either the HH+/HH- or Vin+/Vin- main board connector.

To enable this configuration, take the jumpers stowed on the upper pin on both J15 and J16. Move these jumpers into position so they are contacting both upper and lower pins on J15 and J16. See Figure 2-5 for more details.

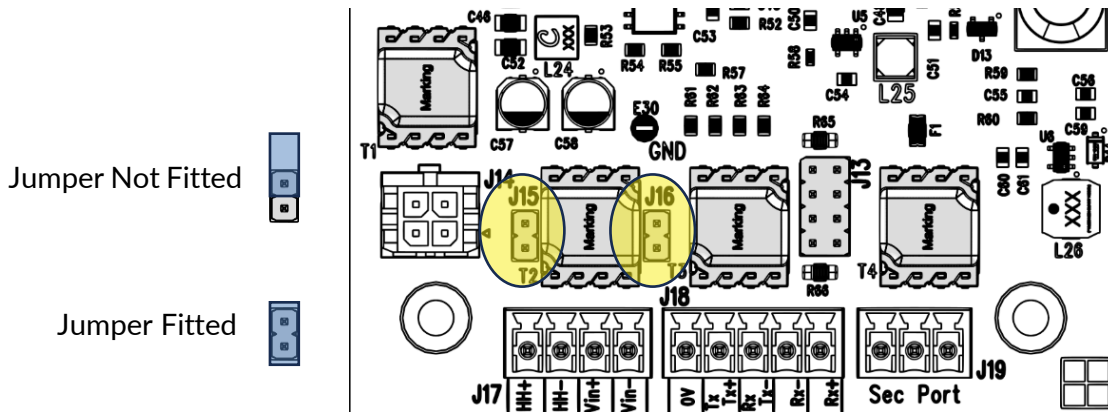

Figure 2-5 Sensor Power Links

For UPS powered applications it is advised to run only the sensor power from UPS to reduce the power consumption from the UPS.

2.5.4 Electrical Earth

WARNING

This sensor **MUST BE EARTHED**. Failure to install a suitable earth may result in inaccurate readings and damage to the sensor. Failure to install an earth when using mains voltages on the relays will make the unit potentially unsafe.

An M6 earth bolt is provided, this is attached to the earth stud. The earth stud is indicated by the Earth symbol located at the front of the case, between the two front lower bracket mounting holes. A 16mm²/6AWG copper wire or equivalent should be attached to the sensor one end and adequately grounded the other end.

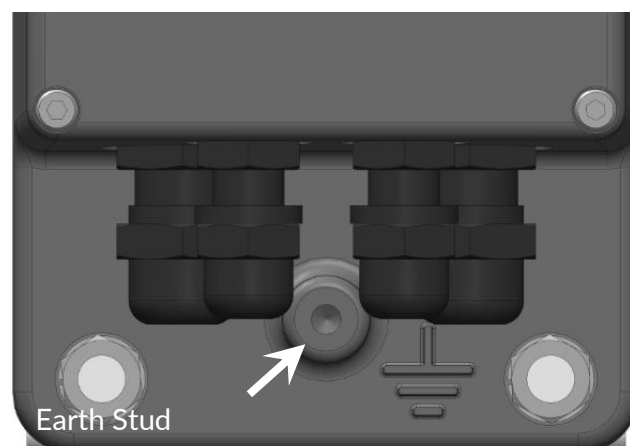

2.5.4.1 Sensor Communication

All RWS sensors are fitted with two communications interfaces, a primary and a secondary. The primary is the main communications line, with the secondary used as an auxiliary interface.

Primary Interface:

The primary interface can be setup as RS232, RS422 or RS485. This is done through the selection of jumpers J11, J12, J13. The default Baud Rate is 9600 for all options, this can be changed as per section 4.2.1.

Connection are as follows:

Mating Connector – Wurth 691361100005

Pin Number	RS232	RS422/RS485
J18 – 1 (0V)	0V	0V
J18 – 2 (TX/TX+)	TX	TX+
J18 – 3 (RX/TX-)	RX	TX-
J18 – 4 (RX-)	-	RX-
J18 – 5 (RX+)	-	RX+

Table 3 Primary Interface Pinout

RS232

If RS232 is selected the jumpers are fitted as follows:

Jumper	State
J11	Fitted
J12	Not Fitted
J13	None Fitted

Table 4 RS232 Jumper Positioning

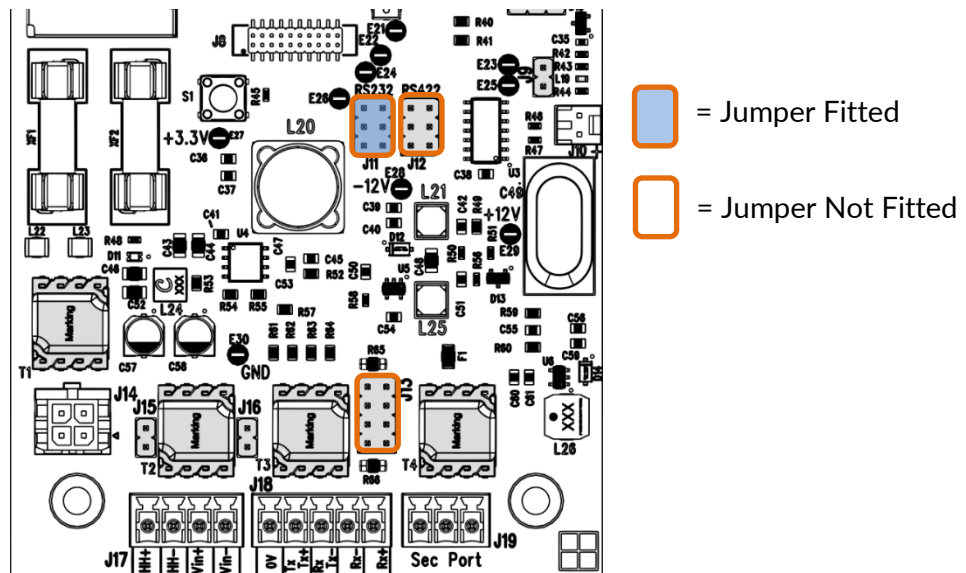

Figure 2-6 RS232 Jumper Configuration

RS232 is only recommended for short runs of less than 15 Metres as it is susceptible to electrical noise.

RS422

If RS422 is selected the jumpers are fitted as follows:

Jumper	State
J11	Not Fitted
J12	Fitted
J13	None Fitted (Default)

Table 5 RS422 Jumper Positions

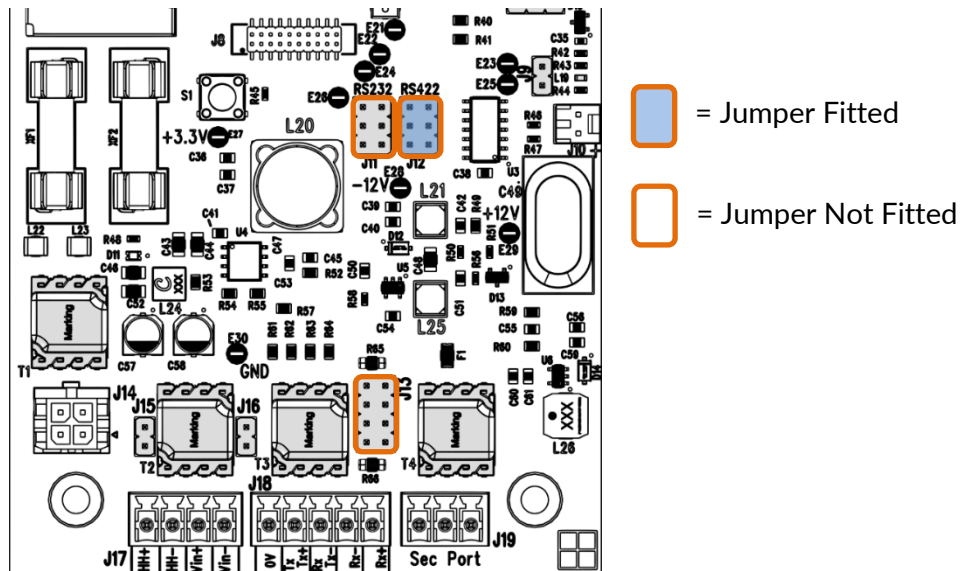

Figure 2-7 RS422 Jumper Positions

By default, J13 is not fitted. This jumper provides optional termination resistors. See configuration options below.

RS485

If RS485 is selected the jumpers are fitted as follows:

Jumper	State
J11	Not Fitted
J12	Fitted
J13	Default None Fitted. For options see next page.

Table 6 RS485 Jumper Positions

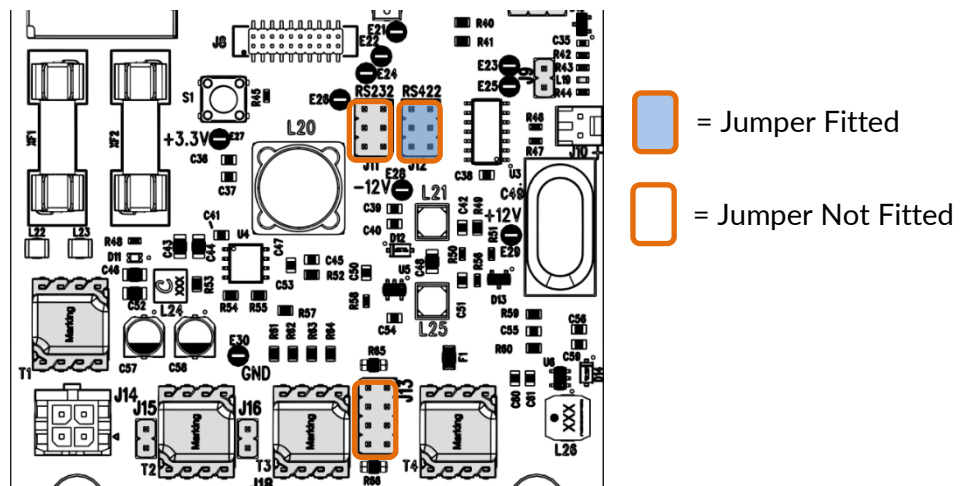

Figure 2-8 RS485 Jumper Positions

By default, J13 is not fitted. This jumper provides optional termination resistors and 2-wire interface.

RS422/RS485 Configuration Options

Termination resistors and 2-wire interface options are available through J13. Jumpers can be placed according to Figure 2-9:

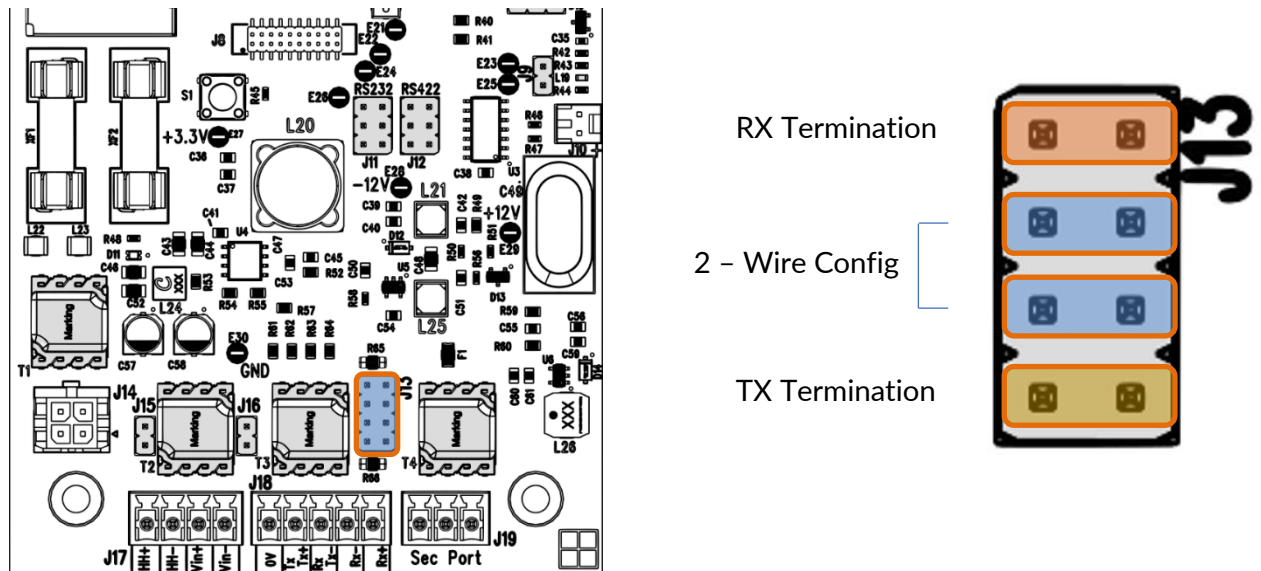

Figure 2-9 RS422/RS485 Configuration Options Jumpers

Secondary Interface:

The secondary interface is an RS232 line with a default Baud Rate of 57600. The intention for the secondary interface is for local programming or redundant communications. See section 4.2 for more details.

Connection to the secondary interface is made as follows:

Mating Connector - Wurth 691361100003

Pin Number	RS232
J17 - 1	0V
J17 - 2	TX
J17 - 3	RX

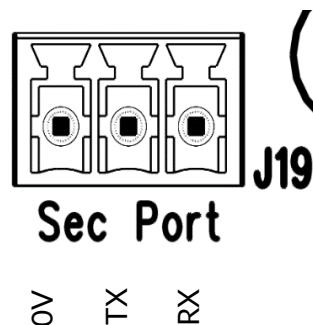

**Note:**

Sending a command over the secondary interface temporarily blocks the primary interface control. See section 4.2.5 for more details.

2.6 Analogues & Relays (AR)

The Analogues & Relay board provides the following functionality:

- 0-20mA OR 4-20mA output
- 0-10V Analogue output
- 3 x Volt free relays (Rated to 250VAC / 2A) (optional extra)

Connection points are shown below:

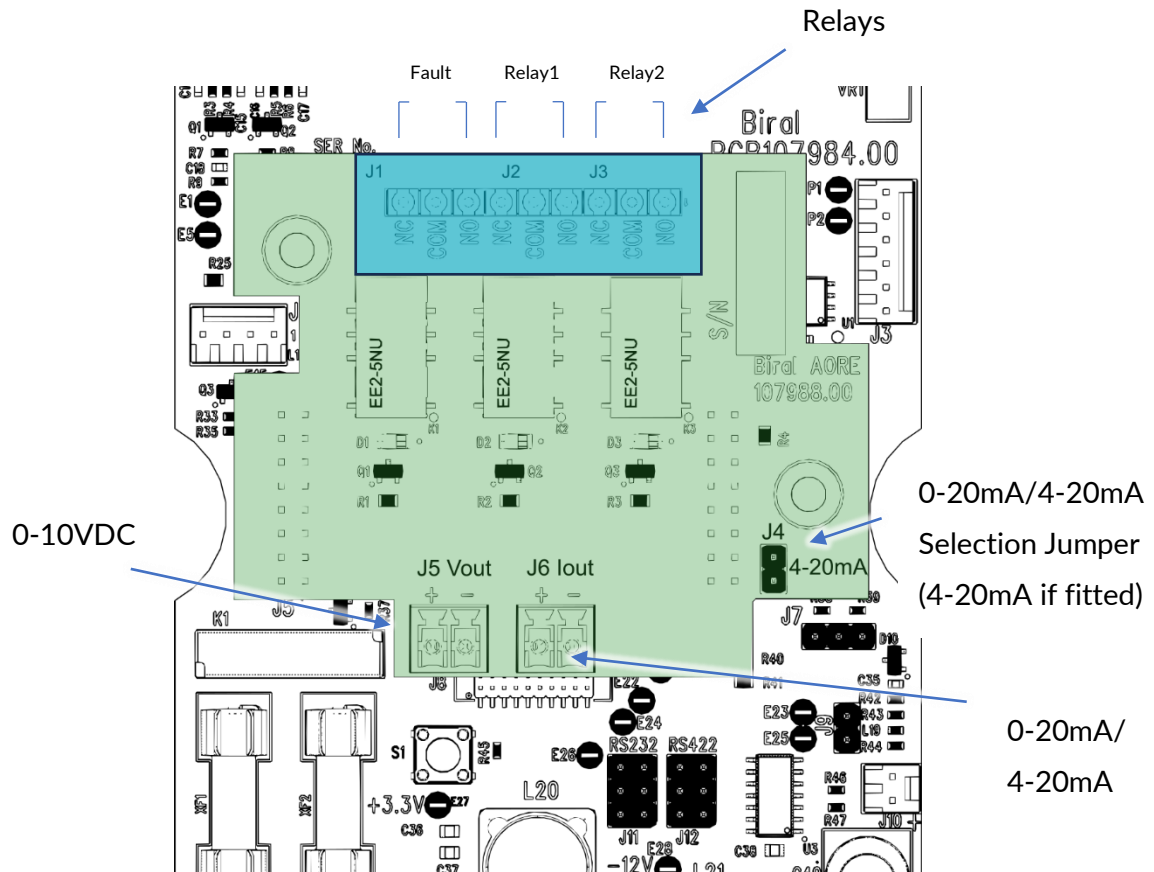

Figure 2-10 AR Board



The connectors accept between 26AWG(0.13mm²) to 16AWG(1.3mm²) wire. The user is responsible for cable selection. If using relays to switch mains voltage the sensor **MUST** be adequately earthed.

Further details of the AR board and setup can be found in sections 3.1, 4.3, 4.5.1.

3 SYSTEM INTEGRATION

Following from Section 2 the sensor should be ready for system configuration/integration.

This section details system integration for:

- Analogue outputs e.g. 0-10VDC, 0-20mA, 4-20mA, Relays
- Serial Interface e.g. RS232, RS422 & RS485

To fully utilise the sensor features it is recommended the sensor is integrated via a digital communications bus. For basic integration the analogue outputs can be used.

Senseca offer a Sensor Interface Software (SIS) free of charge to allow for basic digital communications. This allows the user to send and receive data over a serial bus as well as log data to a file.

3.1 Analogues & Relays

The sensor can be fitted as a standalone system providing analogue outputs without the need for a serial communication bus. Modifications can be made to the analogue output configuration through the serial bus commands – see Section 4.

3.1.1.1 0-10VDC

By default, the 0-10VDC output provides a linear voltage output in the range 0VDC to 10VDC in relation to 0m and MOR_{MAX} . The lowest reported visibility is 10m therefore a small signal will always be present.

See specifications for MOR_{MAX} of the sensor in section 9.1.

Alternatively, the MOR_{MAX} can be modified using the digital communications bus. See section 4.5.1.

3.1.1.2 0-20/4-20mA

By default, the 0-20/4-20mA output provides a linear current output in the range 0/4mA to 20mA in relation to 0m and MOR_{MAX} . The lowest reported visibility is 10m therefore a small signal will always be present.

See specifications for MOR_{MAX} of each sensor in section 9.1.

It should be terminated with a resistance not greater than 500Ω to enable the maximum current of 20mA to be available. The current output does not support loop powered devices.

Either the 0-20mA or 4-20mA range can be selected using jumper J4 on the AR board. See figure Figure 2-10 . Note the sensor must be powered down to change selection.

J4 Jumper	Current Output
Fitted (Default)	4-20mA
Not Fitted	0-20mA

Table 7 0-20/4-20mA Jumper Configuration

Alternatively, the MOR_{MAX} can be modified using the digital communications bus. See section 4.5.1.

3.1.1.3 Relays (Optional Extra)

The relays are triggered by set events. By default, these events are:

Fault Relay	Relay 1	Relay 2
Self-Test Fault	Less than 1km Visibility	Less than 1km Visibility

The Nominally Closed (NC) and Nominally Open (NO) markings on the PCB refer to the relay in the de-energized state.

The Fault Relay is energized by default to provide a fail-safe output, meaning in a non-fault condition the nominally closed pin will be open circuit, and the nominally open pin will be closed circuit in reference to the common pin.

The trigger events for relay 1 and relay 2 can be modified via the digital communication bus. See section 4.3.

3.2 Serial Interface

By default, the RWS-30 sensor is supplied in standard operating mode. In standard operating mode an ASCII data message will be output from the sensor every measurement period (default 60 seconds). The ASCII data message is detailed in Table 8 RWS-30 Operating data message format, each field is comma separated.

3.2.1 Standard Operating Data Message for the RWS-30

The data message format for the RWS-30 is:

RWS-30,NNN,AA.AA KM,CCC.CC,DDD,EE,FF<cs><crLf>

Message	Meaning
RWS-30	RWS-30 message prefix.
NNN	Sensor identification number. Default 000.
AA.AA KM	Meteorological Optical Range (km). This is the averaged value.
CCC.CC	EXCO value. This is the averaged value.
DDD	<p>Self-test and Monitoring (see section 6.2):</p> <pre> DDD ├── O = other self-test values OK. │ └── X = other self-test faults exist. ├── O = windows not contaminated. │ ├── X = window contamination warning - cleaning recommended. │ └── F = Window contamination alert - cleaning required. └── O = sensor not reset since last "R?" command. ├── X = sensor reset since last "R?" command. └── T = sensor in 'test' mode. </pre>
EE	Transmitter Contamination level (%)
FF	Receiver Contamination level (%)
<CS>	If selected this will be the checksum character. The checksum is off by default.

Table 8 RWS-30 Operating data message format

4 ADVANCED SENSOR OPTIONS

The RWS sensor has additional features beyond the scope of the standard data message. Each of these features can be accessed through a series of sensor commands and responses.

Use the table below to view the complete list of commands available. Each command relates to an option which is described in a later section.

4.1 Sensor Commands and Responses



NOTE:

All commands should be terminated with <Carriage Return> and <Line Feed> (<crLf>).

Commands marked with * cause the sensor to restart.

Commands marked with # must be preceded by the CO command.

Command	Function	Section/ Response
ADR?	Query RS485 address.	See Section 4.2.2
ADRxx	Set RS485 address. Range 00-99.	See Section 4.2.2
BAUD3?	Query the secondary serial port Baud rate	See Section 4.2
BAUD3,X	Set the secondary serial port Baud rate	See Section 4.2
BT?	Query instantaneous value of Total EXCO.	See Section 4.5
CE#	Perform both EXCO calibration. (Calibration must be enabled).	See section 7.3
CO	Enable calibration.	See Section 7
CX*	Disable calibration.	See Section 7
D?	Send latest data message.	See section 4.2.4
DHO	Turn hood heaters on for 2 minutes.	See Section 4.4.1
DHX	Turn hood heaters off for 2 minutes.	See Section 4.4.1

Command	Function	Section/ Response
IDx*	Set sensor identification number displayed in data message. Range x = 0 to 999. (Default = 1).	See Section 4.2.6
JRO?	Check Current Relay Configuration. (Relay Option Required)	See Section 4.3
JROx*	Set Current Relay Configuration. (Relay Option Required)	See Section 4.3
KM?	Check current MOR output resolution configuration.	See Section 4.5.2
KMn*	Set MOR output resolution.	See Section 4.5.2
OPCS?	Query checksum option setting.	See Section 4.2.3
OPCSx**	Set checksum option.	See Section 4.2.3
OP485?	Query Addressable 485 communications setting.	See Section 4.2.2
OP485x**	Set Addressable RS485 communications.	See Section 4.2.2
OSAM?	Check automatic message setting.	See Section 4.2.4
OSAMx*	Set automatic message setting.	See Section 4.2.4
OSHH?	Check hood heater setting.	See Section 4.4.1
OSHHx*	Set hood heater setting.	See section 4.4.1
OSWH?	Check window heater setting.	See Section 4.4.2
OSWHx*	Set window heater setting.	See Section 4.4.2.
PV?	Query program version message.	SI xxxx.yy
R?	Send remote self-test and monitoring message.	See Section 4.6
RD?	Query the relay hysteresis time delay.	See Section 4.3

Command	Function	Section/ Response
RDn*	Set the relay hysteresis time delay.	See Section 4.3
RLn?	Check relay 'n' visibility threshold setting.	See Section 4.3
RLHn?	Query the relay threshold hysteresis.	See Section 4.3
RLHn,xx*	Set the relay threshold hysteresis.	See Section 4.3
RLn,XX.XX*	Set relay 'n' visibility threshold in km.	See Section 4.3
RST*	Restart sensor.	OK
SN?	Query sensor serial number.	xxxxx.xx
TEST,tt,vv.vv,f,c,pw**	Set the sensor into a test mode.	See Section 5.1
TM?	Query measurement interval.	See Section 4.5.34.5.3
TMx*	Set measurement interval. Range x = 10-300 (seconds). (Default= 60).	See Section 4.5.3
VIS?	Query the current MOR _{MAX} visibility range	See Section 4.5.1
VIS,XXXXX	Set the MOR _{MAX} visibility range. XXXXX is range in metres.	See Section 4.5.1
WF?	Query Window Contamination Alert Threshold Percentage.	See Section 6.1.3
WFn **	Set Window Contamination Alert. Default 30%.	See Section 6.1.3
WT?	Query current window contamination threshold for warning indication.	See Section 6.1.3

Command	Function	Section/ Response
WTx**	Set window contamination threshold for a warning indication. Default 10%.	See Section 6.1.3
XX	<u>Second Serial Port Only.</u> Used to relinquish control back to primary port.	See Section 4.2.5
YY	<u>Second Serial Port Only.</u> Used to take control from primary port.	See Section 4.2.5
%Bx*	Set Primary communication baud rate. Range: n = 1 to 7.	See Section 4.2.1

Table 9 RWS Sensor Serial Commands

4.1.1 Other Sensor Responses

RESPONSE	MEANING
BAD CMD	The command was not understood by the sensor. Check the text of the command and re-send.
COMM ERR	An error was detected in a character in the command. Re-send the command.
OK	Command with no quantitative response was understood and executed.
TIMEOUT	Command was sent with more than 10 seconds between characters. Re-send the command.
TOO LONG	Command message was longer than 24 characters including end characters. Check the text of the command and re-send.

Table 10 Sensor Responses

4.2 Serial Communications Configuration

By default, the RWS sensor is shipped with RS232 communications. It is possible to change the primary communications to RS422/RS485 through a physical jumper (section 2.5.3).

Other serial communication features available for the RWS sensor are:

- Checksum
- Baud Rate Change
- Address Change
- Polled Mode

A secondary RS232 serial communications bus is available to the user. This does not support RS422 or RS485 communications. Only some of the features are supported by the secondary communications bus, these are detailed in the relevant sections.

4.2.1 Baud Rate Configuration

The Baud rate for both the primary and secondary communication bus can be changed.

Primary Communication Bus

The default baud rate of the primary is 9600. The baud rate may be changed as follows.

Sending %B lists the different baud rate options:

SELECT REQUIRED BAUDRATE BY TYPING %B(NUMBER)

1....1200 BAUD

2....2400 BAUD

3....4800 BAUD

4....9600 BAUD

5....19K2 BAUD

6....38K4 BAUD

7....57K6 BAUD

Sending %Bn

Where n is a number from 1 to 7 will change the Baud rate.

For example, to select 4800 baud the command would be:

%B3

The new setting will only be accepted if the user manages to communicate with the sensor at the new baud rate within 60 seconds. Otherwise, the sensor will reset and continue operation with the original baud rate setting.

If an "OK" command is received at the new baud rate the sensor will update its settings and restart.



Note:

Baud Rate is a trade-off between bandwidth and distance. The higher the Baud Rate the more frequent messages can be sent/received but the shorter the transmission line can be.

Secondary Communication Bus

The default baud rate of the secondary is 57600. The baud rate of the secondary serial port can be changed using the following command: BAUD3,n where n is the desired baud rate.

The list of baud rates supported by the secondary port are:

- 9600
- 19200
- 38400
- 57600
- 115200

For example, to select 9600 baud the user would type:

```
BAUD3,9600
```

For changes to take place a sensor reset is required. This can be done through the RST command.

Typing BAUD3? queries the current baud rate of the secondary port.

4.2.2 RS485 Communications

The primary communication bus can be configured for addressable RS485 communications. The jumper must be configured for RS422/RS485 as per section 2.5.3.

RS485 Current Settings

To query the RS485 setting, send the following command: OP485?

The sensor will respond with:

00	= Disabled
01	= Enabled

Enable RS485 Communications

To enable RS485 communications, send the commands: CO followed by OP4851

The sensor will respond and reset for changes to take effect.

Disable RS485 Communications

To disable RS485 communications, send the commands: CO followed by OP4850

The sensor will respond and reset for changes to take effect.

RS485 Protocol Format

The RS485 communication protocol is based on the Modbus ASCII Frame Format.

Each data request and transfer is configured as follows:

Start:	':' (3A Hex).
Sensor Address:	2 Character address field.
Data:	RWS message format, see Section 3.2 OR Any RWS command/response
LRC Checksum:	2 Characters - Longitudinal Redundancy Check.
End:	2 Characters - Carriage return + Line Feed.

Start

The ':' (colon) symbol is used as a start flag which is 3A Hex.

Sensor Address

The 2 character sensor address is defined by the operator for the unit and programmed as specified later in this section. It can be any numeric value between 00 and 99.

Data

This is a variable length ASCII character string. See list of command and responses. If configured as standard operating mode, the standard data message will be output every measurement period.

It is recommended that the sensor is configured as polled mode whilst in RS485 communications mode to prevent data clashing on the RS485 bus with multi-drop applications.

LRC Checksum

This enables error checking, allowing the master to request a re-send if errors are detected. For RS485 a Longitudinal Redundancy Check (LRC) Checksum is generated on the data.



NOTE:

This checksum is different from the optional RS232/RS422 Checksum.

The LRC is one byte, containing an 8-bit binary value. The LRC value is calculated by the transmitting device, which appends the LRC to the message. The receiving device calculates an LRC during receipt of the message and compares the calculated value to the actual value it received in the LRC field. If the two values are not equal, an error is implied, and the message is discarded.

The LRC is calculated by adding together successive 8-bit bytes of the message, discarding any carries, and then two's complementing the result. It is performed on the ASCII message field contents excluding the 'colon' character that begins the message and excluding the <crLf> pair at the end of the message. The LRC byte is converted to 2 ASCII characters and appended to the message.

For example, the message:

:42D?

Checksum is calculated as :

ASCII string 42D?

BYTE Values (in Hex) 34+32+44+3F

Sum is E9

One's compliment (0xFF - 0xE9) = 0x16

Two's compliment 0x16 + 1 = 0x17

Checksum is 0x17 (Hex)

Checksum ASCII characters are "17"

Transmitted string will therefore be:

:42D?17<CRLF>

End

All communications will end with the standard 2 characters, carriage return + line feed <CRLF> pair (ASCII values of 0D & 0A Hex).

Checksum Override

When using RS485 communications, the sensor will disregard any commands that do not have the correct sensor address or have an incorrect checksum.

If the checksum character is set to FF then the sensor will accept the message without checking the checksum. This is useful for diagnostics. For example,

a sensor with address 00 to request a data message:

Send command:

:00D?FF

RS485 Address

The RS485 address can be set by the user. To query the current address the command: ADR? can be used.

To set the RS485 address the command: ADRxx should be used, where xx denotes the address between 00 and 99.

Recommendations

When using the sensor on an RS485 network it is recommended that the sensor be set up in polled mode (Automatic message transmission disabled) rather than transmitting a data message automatically.



Note:

When RS485 communications are enabled, the sensor will not output the “Biral Sensor Startup” message on power up and reset.

4.2.3 Message Checksum

A checksum byte can be included with messages sent by the sensor to verify that noise in the communications link has not changed the message. This is only applicable to the primary interface port. Generally, noise is not a problem and checksum verification is not required.



NOTE:

if RS485 communications are selected then this checksum is not used as it is built into the RS485 protocol itself.

By default, the sensor is configured at the factory with checksum DISABLED.

To check the setting of the checksum option, send the command: OPCS?

The sensor will respond as follows:

00 = Checksum disabled
01 = Checksum enabled

To enable the checksum, send the commands: CO followed by OPCS1

To Disable the checksum, send the commands: CO followed by OPCS0

The checksum character is positioned after the message and before the end characters (<crLf>). The checksum value is between 0 and 127 and is the sum modulo 128 (the remainder after the sum is divided by 128) of all the ASCII values of the characters in the message except the end characters.

The checksum value is replaced by its bit wise complement if it happens to be any of the following: ASCII 8 (backspace), ASCII 10 (linefeed), ASCII 13 (carriage return), ASCII 17 through ASCII 20 (DC1 through DC4), or ASCII 33 (exclamation point '!').

4.2.4 Automatic Message Setting / Polled Mode

The sensor can be set to send a data message automatically after each data measurement period, or to send a data message only when requested (polled mode). The default setting is for automatic data transmission.

In automatic message mode the sensor will average over the measurement period. In polled mode the sensor will average visibility over the polled period (defined by the user). A minimum of 10 seconds and maximum of 5 minutes between sensor message queries is allowed. If the sensor is polled before 10 seconds or beyond 5 minutes the data may not be accurate.

To check which method is programmed send the message:

OSAM?

The sensor will send the reply:

00 = Automatic message transmission disabled
01 = Automatic message transmission enabled

To set the sensor to the required automatic message setting, send the message:

OSAMx

Where x is:

0 = Automatic message transmission disabled
1 = Automatic message transmission enabled

The sensor will respond with "OK".

To receive data in polled mode the command "D?" must be sent.

In polled mode, on each D? command the sensor recalculates the visibility since the last “D?” command.

4.2.5 Secondary Serial Port Operation

The second serial port duplicates the primary port output for transmitted data when the primary port is in control. Note, if the checksum option is configured only the primary output will contain the checksum within the string.

The primary serial port will duplicate the secondary port output for transmitted data when the secondary port is in control. Note, if the checksum option is configured only the primary output will contain a checksum within the string.

The primary port will not respond to commands when the secondary port is in control.

Passing Control Between Primary and Secondary Communication

To prevent clashes between primary and secondary communication ports, control of the RWS can only be achieved by one port at a time. This is especially important if a firmware update is in progress.

Control will pass between ports under the following conditions:

Port Currently in Control	Conditions for Switching Control
Primary	YY command received on the secondary port
Secondary	After 5 minutes of inactivity. i.e. no commands issued to the secondary serial port
Secondary	XX command received on the secondary port
Secondary	Sensor reset

Table 11 Control Between Primary and Secondary Comms

For example, for a user to start sending commands on the secondary port a YY command must first be sent.

The primary port will continue to output data when the secondary port is in control. This includes the response to any commands received on the secondary port.

4.2.6 Sensor Identification Number

For users with multiple RWS sensors, it is possible to set individual sensor identification numbers. The sensor identification number is included in the standard operating message.

To set the sensor identification number use the command:

IDx where x is the desired identification number between 0 and 999.

The sensor will reset following this command.



WARNING:

Failure to install a protective earth will make the unit potentially unsafe when using the relays to switch hazardous voltages.

4.3 Analogues & Relays Configuration

The RWS can be purchased with relay options. This allows for easy interfacing of external equipment through volt-free contacts.

To get the current relay configuration send the command JRO?

The sensor will respond with a number which corresponds to:

Value	Description
0	No Relays Configured.
2	Fault Relay, Relay 1 triggered on visibility (default 1km) and Relay 2 triggered on visibility(default 1km).
4	Fault Relay, Relay 1 triggered on visibility (default 1km) and Relay 2 triggered on window contamination warning.

Table 12 Relay Configuration

The default value is set to 2 if the relay option has been purchased.

To change the configuration

To change the relay configuration, send the command JROx

where x is the value from the table above.

e.g. JRO2

Configures Relay 2 to be a second visibility relay.

To read the visibility Threshold levels

To read the visibility threshold levels for Relay 1 and Relay 2 send the following command:
RLn?

where n is the relay number (either 1 or 2).

The sensor will respond with the visibility threshold in km.

e.g. 1.00 km

The default threshold is 1km.

To change the visibility Threshold levels

To change the visibility threshold levels for relay 1 or relay 2 send the following command:
RLn,xx.xx

where n is the relay number (either 1 or 2)

and xx.xx is the threshold level in km. Range 0.10 to 99.99km.

e.g. to set the threshold for relay 1 to 1km send the command:

RL1,1.00

To read the relay switching delay

To ensure the relays do not continually switch, for example when the visibility fluctuates around the switching point, a time delay is utilised. The time delay applies to switching on and switching off of all relays. The default delay is 4 minutes. To view the delay time, send the following command: RD?

The sensor will respond with the delay time in minutes.

It is possible to control individual relay switch on and off timings, for more information contact Senseca.

To set the visibility threshold switching delay

Send the command: RDxx

Where xx is the required delay in minutes. Range 1 to 15 minutes.

To read the visibility threshold switching hysteresis

To ensure the visibility threshold relays do not continually switch when the visibility fluctuates around the switching point a signal hysteresis is provided as a percentage of the threshold. For example, if threshold is set to 1km and the hysteresis value is 20%, when visibility is decreasing the relay will switch on as the visibility drops below 1km. When the visibility is increasing the relay will switch off at 1.2km; the threshold plus the hysteresis value. The hysteresis value can be set independently for each visibility threshold relay; the default value is 20% of the threshold.

To read the hysteresis value for a relay, send the following command: RLHn?

Where n is the relay number.

The response is:AAA%,BBB.BBkm

Where: AAA is the hysteresis value as a percentage of the threshold.

BBB.BB KM is the calculated visibility off threshold.

To set the visibility threshold switching hysteresis

Send the command: RLHn,xx

Where: n is the relay number.

xx is the threshold hysteresis value. Range 5 – 25%.

4.3.1 Analogue Output

The analogue outputs are scaled according to the maximum visibility of the sensor. The maximum visibility of the sensor can be adjusted according to section 4.5.1.

By default, the analogue outputs are configured for visibility (MOR) to provide a linear response across the sensor range. To increase the output resolution at lower visibilities it is possible to configure the output to utilise the EXCO. For more information contact Senseca.

Use the following formula to convert voltage or current readings to MOR.

	0-10V	4-20mA	0-20mA
MOR output	$MOR = (Range/10) * V_{out}$	$MOR = (Range/16) * (I_{out} - 4)$	$MOR = (Range/20) * I_{out}$

Range = The maximum configured range of the sensor, see section 4.5.1

V_{out} = The voltage across the 0-10V output terminals

I_{out} = The current flowing through the 4-20mA terminals in milliamps

EXCO Output

To increase the analogue output resolution at lower visibilities it is possible to switch the output to use the EXCO. To do so use the commands:

AN1 - Analogue outputs to use EXCO

AN0 - Analogue outputs to use MOR (default)

To calculate the EXCO use the formula:

$$EXCO = 3/MOR$$

Note, the maximum EXCO is related to the minimum visibility of the sensor. For the RWS-30 the minimum visibility is 200m, having an equivalent EXCO of 15. The maximum EXCO is fixed and cannot be changed. The minimum EXCO will be related to the maximum visibility of the sensor. For the RWS-30 the maximum visibility is 99.9km, having an equivalent EXCO of 0.03. The minimum EXCO will change with the maximum visibility as set through the **VIS** command, see section 4.5.1.

	0-10V	4-20mA	0-20mA
EXCO output	$EXCO = (15/10) * V_{out}$	$EXCO = (15/16) * (I_{out} - 4)$	$EXCO = (15/20) * I_{out}$

4.4 Sensor Heater Options

The RWS is fitted with window heaters and hood heaters (if purchased) to prevent environmental conditions from affecting the measurement. In certain circumstances it may be beneficial to the user to be able to control these heaters.

The window heaters are low power and prevent dew on the windows from interfering with the measurements. The window heaters provide enough heat to evaporate small droplets that may reach the windows. The window heaters are powered directly from the sensor supply.

The hood heaters are higher power heaters fitted into the inside of the hoods. These prevent ice/snow build up from interfering with the measurement. The heaters are supplied by a separate 24VDC power supply from the sensor. This is to allow for system integrators to use smaller UPS systems where a backup is required for the main sensor.

4.4.1 Hood Heaters (Heated Option)

By default, the hood heaters are set to work automatically. In automatic mode the hood heaters turn on at 2 degrees, off at 4 degrees.

If desired, the sensor can be set to have the hood heaters disabled. To check which configuration is programmed send the message:

OSHH?

The sensor will send the reply:

00 = Hood heaters disabled

01 = Hood heaters on automatic

To set the sensor to the required hood heater configuration, send the message:

OSHHx

Where x is:

0 = Hood heaters disabled

1 = Hood heaters on automatic

The sensor will respond with "OK".

If hood heaters are enabled, they can temporarily be controlled using the commands DHX and DHO.

To temporarily enable the hood heaters for 300 seconds, use the command DHO.

To temporarily disable the hood heaters for 300 seconds, use the command DHX.

4.4.2 Window Heaters

By default, the window heaters are set to be permanently enabled. The sensor can be set to have the window heaters disabled, permanently enabled, or for them to be controlled according to contamination levels. To check which configuration is programmed send the message:

OSWH?

The sensor will send the reply:

00 = Window heaters disabled

01 = Window heaters enabled and on (default)

02 = Window heaters enabled and controlled according to contamination levels

To set the sensor to the required window heater configuration, send the message:

OSWHx

Where x is:

0 = Window heaters disabled

1 = Window heaters enabled and on

2 = Window heaters enabled and controlled according to contamination levels

The sensor will respond with "OK".

Where controlled by contamination levels the heaters will come on at the warning level threshold (default 10%) contamination. This can be set as per 6.1.3.

4.5 Visibility Settings

The RWS sensor allows for the following to be configured:

- Visibility Range
- Visibility Resolution

It is also possible to query the instantaneous EXCO using the command:

BT? - Forward Scatter EXCO

The instantaneous EXCO is based on the latest visibility data saved within the sensor memory and is not adjusted for window contamination.

4.5.1 Visibility Range

The RWS-30 is delivered with a default visibility range of 99.99km configured. It is possible for the user to modify the visibility range of the sensor from default using the command:

VIS,XXXXX

Where XXXXX is distance in meters. E.g. VIS,5000 sets the range to 5km. This can be set anywhere between 1,000m and 99,990m

When modifying the maximum visibility this will correspond to the MOR_{MAX} used by the analogue outputs.

To query the current visibility setting use the command:

VIS?

4.5.2 MOR Output Resolution

In the factory default setting the Meteorological Optical Range (MOR) values output in the data messages are expressed in kilometres to a resolution of 10m. The output can also be expressed in metres to a resolution of 1m or kilometres to a resolution of 1m. Note this will change all MOR readings in all messages.

Changing the output format of the MOR value does not affect the EXCO output field in the sensor data message.

Querying the MOR Output Resolution

To query the MOR output resolution, send the KM? command. The sensor will respond with two characters as shown below:

00 Default Setting, MOR expressed in km to 10m (xx.xx KM)

01 Metre output, MOR expressed in m to 1m (xxxxx M)

02 Kilometre output, MOR expressed in km to 1m (xx.xxx KM)

Setting the MOR Output Resolution

To set the MOR resolution send the KMn command, with n set as follows:

- KM0 Default Setting, MOR expressed in km to 10m (xx.xx KM)
- KM1 Metre output, MOR expressed in m to 1m (xxxxx M)
- KM2 Kilometre output, MOR expressed in km to 1m (xx.xxx KM)

 NOTE:

The sensor will undergo a soft reset when the command is processed.

4.5.3 Measurement Period Configuration

At the end of each measurement period there will be an automatic output of the standard operating data message if the sensor is in automatic messaging mode.

The measurement period command **TMx** will set the measurement period for all visibility related measurements. It is recommended that this is set to 60 seconds (default).

In the event of polled mode, the measurement period is overwritten by the user polling frequency.

To set the measurement period use the command:

TMx

where x is the measurement period in seconds (min 10, max 300)

To query the current measurement period, use the command:

TM?

where the response is the current measurement period in seconds.

4.6 Sensor Status

To query the sensor status use the “R?” command. This should be used if an “X” appears in the self-test status of the standard operating message.

The various fields in the response are as follows:

Field	Range / Value	Description
Field 1:	Space	The message starts with a space.
Field 2:	ABC	Heater state and error flags.
		A = 1 - Window heaters ON.
		A = 2 - Hood Heaters ON.
		A = 4 - A/D control signal error.
		B = 1 - EPROM checksum error.
		B = 2 - Non-volatile memory checksum error.
		B = 4 - RAM error.
		B = 8 - Not used.
		C = 2 - Ired commanded OFF.
		C = 4 - Receiver test in progress (Ired OFF).
		C = 8 - Sensor power reset since last R? Command.
Field 3:	1.19 - 1.31	Internal reference voltage.
Field 4:	9.00 - 36.00	Supply voltage.
Field 5:	11.2 - 13.0	Internal operating voltage.
Field 6:	3.0 - 3.5	Internal operating voltage.
Field 7:	11.2 - 13.0	Internal operating voltage.
Field 8:	0.00 - 6.00	Forward scatter background brightness.
Field 9:	0.00	Not used
Field 10:	85 - 105	Transmitter power monitor.
Field 11:	80 - 120	Forward receiver monitor.
Field 12:	100	Not used
Field 13:	00 - 99	Transmitter window contamination.
Field 14:	00 - 99	Forward receiver window contamination.
Field 15:	00	Not used
Field 16:		Temperature °C.
Field 17:	3300-4200	ADC interrupts per second.

Table 13 R? Command Response

5 TEST MODE

To aid with full system testing the RWS features a TEST mode. This is intended to emulate environments the RWS will observe, e.g. low visibility.

5.1 Test Command

If you wish to test the connections to the serial outputs of the sensor, use the TEST command. This command allows the sensor to be set to a known condition for a set period of time allowing the unit to temporarily simulate foggy and clear conditions, which will allow checking of the sensor and overall system performance.

Command Syntax

To ensure the TEST command is not used inadvertently it must be preceded by the Calibration Enable command, CO.

The TEST command takes the following form:

```
TEST,tt,vv.vv,f,c<CRLF>
```

Where:

- tt Duration of test in minutes – range 00 to 60, (00 will stop the test).
- vv.vv Visibility in km
Range 0.01 to maximum range of sensor.
- f State of the Other Self test digit in the Self test & Monitoring field of the data message.

0 = No Fault,
1 = Other self test fault exists.
- c Window Contamination Indicator digit in the Self test & Monitoring field of the data message.

0= Windows not contaminated
1= Window Contamination Warning
2= Window Contamination Alert.

Example:

TEST,02,07.50,0,0,00 – Outputs a visibility of 7.5 km for 2 min (Clear conditions)

TEST,06,00.10,0,0,30 – Outputs a visibility of 0.1 km for 6 min (Foggy conditions)

Command Operation

Where trailing fields of the TEST command are omitted they will be automatically substituted by the value zero.

Example:

TEST,5,2.34<CRLF> (Sets the visibility to 2.34km for 5 minutes)

has the same meaning as,

TEST,5,2.34,0,0

Where a parameter is outside of the allowable range for the configuration of the sensor, the sensor will respond with BAD CMD. For example, if a RWS-30 has been configured to have a maximum reporting range of 2km and the TEST command states 5km the sensor will respond with BAD CMD.

At the end of the test period, or when the test period is terminated using TEST,0, the sensor will undergo an automatic soft reset.

For the duration of the test output the first character of the Self test & Monitoring field of the data message will be set to T. This allows the system to which the sensor is connected to be aware that the data message contains test values and should not be used operationally.

6 MAINTENANCE PROCEDURES

The RWS series of sensors require very little maintenance. The following sections detail the checks that are advisable to ensure continued good operation of the sensor. The frequency of these checks depends upon the location and environmental conditions under which the sensor operates.

It is suggested that a general check, plus window cleaning should take place typically at three monthly intervals. This period may be increased or decreased dependent on the contamination determined during these inspections. It is also recommended that a calibration check (See Paragraph 7.2) is carried out at six monthly intervals to verify that the sensor is continuing to perform within the specification.

Section 6.2, Self-Test Codes, describes the meaning of the self-test codes provided in all the standard data messages. It specifies what actions, if any, are required to restore the sensor to full operational capability.

6.1 General Checks

A general check of the physical condition of the sensor should be carried out at regular intervals. Particular attention should be paid to the condition of the cable(s) from the base of the unit. It is suggested that this is carried out at least every three months, in conjunction with window cleaning (see 6.1.3 below).

6.1.1 De-mister Heaters

The window de-misters are low powered heaters designed primarily to prevent condensation. They maintain the temperature of the windows at a few degrees above ambient temperature.

The warmth may be detected with the finger on the window but is easier to detect using a thermometer with surface temperature probe. The windows should be between 2°C and 8°C above ambient temperature after at least 10 minutes operation. Ensure that windows are cleaned after coming into contact with the skin.

6.1.2 Hood Heaters (optional)

Hood heaters are fitted to the inside of each of the hoods. See Figure 6-1 Hood Heater.

The hood heaters are high-power heaters designed to prevent the build-up of frozen precipitation in the hoods. These heaters operate according to the ambient temperature, only being switched on when the temperature is below 2°C and off again at 4°C. When switched on, it is easy to detect the heating by placing a finger on the end of each hood. The heaters may be switched on temporarily using the command DHO and off again using the command DHX, see Section 4.4.

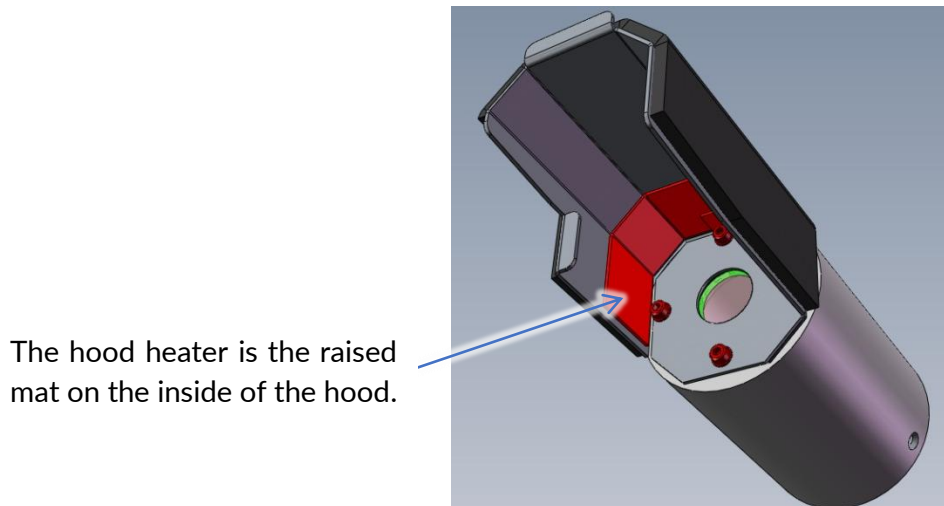

Figure 6-1 Hood Heater

6.1.3 Window Cleaning

RWS sensors are optical instruments and are therefore susceptible to accumulation of contaminants on the windows in the hoods. The windows should be cleaned by gently wiping the windows using a mild detergent solution or pure alcohol (propanol) and a soft cloth (*appropriate safety precautions must be taken when using pure alcohol*).

The self-test of the sensor will also report if the windows need to be cleaned more frequently.

It is possible for the user to modify the window contamination alert thresholds if desired. The commands WF? And WT? allow for the alert threshold (WF?) and warning threshold (WT?) to be read from the sensor. By default, the alert is 30% and the warning is 10%. Setting the alert above 30% will reduce the sensor accuracy.

To modify the thresholds, use the CO command followed by:

- WFn where n is between 0-99
- WTn where n is between 0-99

The sensor will reset for the new settings to be saved.

6.2 Self-Test Codes

Self-Test and Monitoring information is provided in the standard Operating Data Message. This information consists of three alpha-numeric characters which have the following meanings.

! NOTE:

The command "R?" provides a response with full diagnostic information. The extent of this information depends on the sensor configuration specified at time of purchase.

6.2.1 Most Significant Character (Sensor Reset Flag)

This will be set to “X” on start-up. It will only be set to “O” following receipt of an “R?” command. If it subsequently is set to “X”, this is an indication that the sensor has reset. This is generally of no importance but may assist in the diagnosis of other problem associated with the installation such as unexpected power dropouts.

If the sensor is in test mode this will be set to “T”.

6.2.2 Central Character (Window Contamination)

All RWS sensors have transmitter window contamination monitoring and EXCO compensation. If selected at the time of purchase, the advanced self-test monitors both transmit and receiver windows to provide a superior window contamination detection and compensation techniques.

The sensor checks the contamination figure against a warning limit, WT, (default 10%) or the alert limit, WF, of (default 30%). This Self-test code can be one of three characters, O, X or F dependent on the contamination reading received. These have the following meaning:

- “O”: Window contamination is less than warning threshold on all monitored windows. No action required.
- “X”: Window contamination warning. The window contamination is between WT and WF on one or more monitored windows and below WF on all monitored windows. The visibility reading provided is corrected utilising this contamination figure, but it is recommended that the windows are cleaned at the earliest possible opportunity.
- “F”: Window contamination alert. The window contamination is above WF on one or more monitored window. Although the visibility reading is still corrected using this contamination figure, the accuracy may deteriorate as the contamination increases. The windows require cleaning.

The values of WT and WF can be queried and set using the WT and WF commands as described in section 6.1.3.

6.2.3 Least Significant Character (Other Self-Test errors)

A variety of operating parameters are regularly checked against normal operational figures as an early warning of possible sensor faults. This character indicates whether all parameters other than window contamination are normal. This Self-test code can be O, X, or F. These have the following meaning:

- | | |
|-------|--|
| “O”: | No Fault. No action required. |
| “X”: | Internal error. Send command “R?” to list all internally monitored parameters and diagnose according to section 4.6. Send command “RST” to restart the sensor. If the fault persists, arrange for the sensor to be serviced at the earliest possible opportunity. |
| “F” : | This indicates that the Forward scatter receiver is saturated with a bright light source (such as direct view of the sun). The sensor is unable to operate under these conditions and will report 10m visibility. To prevent saturation, the sensor should be repositioned (see section 2.3) to prevent this occurrence. |

6.3 Baud Rate Recovery

It is possible to force the sensor to boot at the default baud rates by placing a jumper across J9 on the main processor board. For the primary port this is 9600, for the secondary port this is 57600. This can be used in the event the baud rate settings have been changed from default and subsequently forgotten.

For any user configured Baud rate to take effect the jumper must be removed.

7 CALIBRATION PROCEDURES

This section explains how to CHECK the calibration of the sensor and ONLY IF NECESSARY how to recalibrate it.

**ALL THE PROCEDURES IN THIS SECTION REQUIRE
A SWS CALIBRATION KIT**



WARNING:

ENSURE THE CORRECT MODEL AND REVISION OF CALIBRATION KIT IS AVAILABLE.

Use of the wrong calibration kit will result in incorrect calibration of the sensor.

See section 7.1 for details.

The calibration of the EXCO for all sensors are checked using the procedure detailed in section 7.2.

The Calibration Reference Plaque has been assigned a forward scatter calibration value and a backscatter calibration value. These values are shown on the label on the arm of the Calibration Reference Plaque.

Each Calibration Reference Plaque also has a MOR equivalent value assigned to it. This value is shown on the surround of the Calibration Reference Plaque.

All calibration values can also be found on the Calibration Certificate provided with the Calibration Kit.

7.1 Calibration Plaque Identification

Only the Calibration Kit designed for use with the SWS sensor family should be used. Use of a Calibration Kit intended for use with another sensor family is not possible due to the unique mounting arrangements. Any attempt to use an incompatible Calibration Kit may result in damage to the sensor and Calibration Kit. The carry case of the SWS Calibration Kit is fitted with a label stating, “SW Calibration Plaque” or “SWS.CAL”.

In January of 2014 the main IRED light source of the RWS sensor family was changed from a device operating at 880nm to one operating at 850nm; this change was necessary due to component obsolescence. A consequence of the change of wavelength is that calibration plaques intended for use at 880nm are not compatible with sensors operating at 850nm and vis versa.

To ensure that it is not possible to use an incompatible calibration plaque the alignment features that control the fitting of the plaque to the sensor and the fitting of the plaque disk to the plaque arm are different on plaques intended for 880nm use compared to those intended for 850nm use.

IF THE PLAQUE DOES NOT FIT EASILY ON TO THE SENSOR IN THE CORRECT POSITION IT IS NOT COMPATIBLE WITH THE SENSOR.

UNDER NO CIRCUMSTANCE MUST THE PLAQUE BE FORCED INTO POSITION OR THE ALIGNMENT FEATURES BE TAMPERED WITH.

To provide a quick and simple method of checking the compatibility of a plaque with a sensor the colour of the sensor label, Calibration Kit case and plaque metalwork are used. See the table below for details.

Feature	880nm	850nm
Sensor Label	White	Silver
Calibration Kit box colour	Black	Blue
Calibration plaque frame colour	Black	Silver

7.2 Calibration Check

The following instructions show how to check the calibration of a SWS series sensor. This procedure can only be completed with:

1. A SWS Calibration Kit.
2. Connection to a PC running the Sensor Interface Software, or, if this is not available, terminal emulation software using the serial connection. *If you need help with this, please do not hesitate to contact us (contact details on page vii).*

CALIBRATION CHECK NOTES

PLEASE READ THESE NOTES BEFORE CONTINUING

The MOR (Meteorological Optical Range or visibility) values depend heavily on the location and prevailing weather conditions and should only be carried out with the sensor:

1. **MOUNTED OUTSIDE AND ON A CLEAR DRY DAY (VISIBILITY = 7.5KM)**
2. **POWERED FOR AT LEAST 1 HOUR**
3. **NOT LOCATED NEAR A WALL OR OTHER OBSTRUCTION**
4. **NOT RECEIVING OPTICAL REFLECTIONS (FROM SURFACES OR CLOTHING)**

Figure 7-1 Assembly of Calibration Reference Plaque (Example of plaque in-situ on SWS-200)

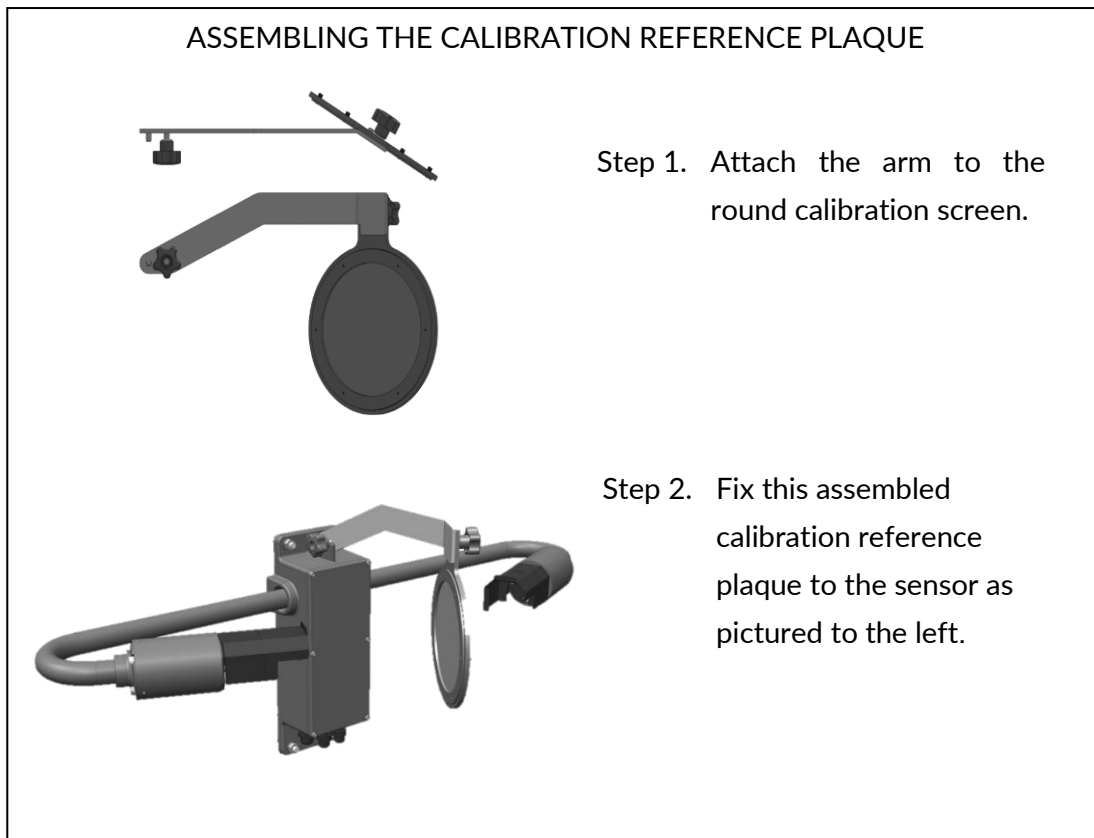

Figure 7-2 RWS Calibration Plaque Assembly

 NOTE:

All commands should be terminated with <Carriage Return> and <Line Feed> <crLf>

STEP 1: Clean all windows on the sensor using a mild detergent solution or pure alcohol (propanol) and soft cloth or tissue, preferably lens tissue. Check the cleanliness using a portable light if possible.

STEP 2: Attach the calibration reference plaque to the sensor as shown in **Error! Reference source not found.**7-1. Power to the sensor need not be removed. Do not stand close to the sensor during calibration as reflections may cause errors in the reported values.

Zero Check:

STEP 3: Insert GREY FOAM PLUGS in the front of each window blocking out all light.

STEP 4: Send the command "RST". Verify the response "OK".

STEP 5: If the sensor is operating in the polled mode, send the "D?" command at 60 seconds intervals. If the sensor is set to automatically output data, then the sensor will output data every 60 seconds.

STEP 6: Wait for the fifth (5th) data message from the sensor. Send the command "BT?". Verify that the response value is between 0.00 and 0.05.

STEP 7: Remove the foam plugs.

Gain Check:

STEP 8: Send the command "RST" to restart the sensor.
Verify the response is "OK".

STEP 9: If the sensor is operating in the polled mode, send "D?" command at 60 seconds intervals. If the sensor is set to automatically output data, then the sensor will output data every 60 seconds.

STEP 10: Wait for the fifth (5th) data message from the sensor. Send the command "BT?". Verify that the response value is within $\pm 10\%$ of the forward scatter calibration value assigned to the Calibration Reference Plaque.

STEP 11: Remove the calibration reference plaque from the sensor.

If the results of the calibration check have agreed with the value on the label attached to the calibration reference plaque within the limits stated above, re-calibration is NOT required.

A re-calibration is required ONLY if the MOR values are outside those on the calibration reference plaque AND the calibration check has been carried out ACCORDING TO THE CALIBRATION CHECK NOTES.

7.3 Sensor Re-Calibration

**RE-CALIBRATING THE METEOROLOGICAL OPTICAL RANGE
SHOULD ONLY BE CARRIED OUT IF THE SENSOR HAS FAILED A
CORRECTLY PERFORMED USER CONFIDENCE CHECK**

WARNING
**ERRORS DURING THIS RE- CALIBRATION PROCEDURE WILL CAUSE THE
SENSOR TO GIVE INCORRECT DATA**

BEFORE CONTINUING ENSURE THAT THE SENSOR:

- 1. IS MOUNTED OUTSIDE AND THAT VISIBILITY IS 7.5KM.**
- 2. THERE IS NO PRECIPITATION**
- 3. HAS BEEN IN CONTINUOUS OPERATION FOR AT LEAST 1 HOUR.**
- 4. WINDOWS ARE CLEAN**
- 5. IS NOT LOCATED NEAR A WALL OR OTHER OBSTRUCTION**
- 6. IS NOT RECEIVING OPTICAL REFLECTIONS (from surfaces or clothing)**

- STEP 1.** Set up the sensor with the calibration reference plaque in place see section 7.2. Power to the sensor need not be removed.
- STEP 2.** Send command CO.
Sensor replies: OK.
- STEP 3.** Send command: CE.
The sensor will reply:
CLEAN WINDOWS,
BLOCK FWD SCAT RCVR OPTICS,
BLOCK TRANSMITTER OPTICS
INSTALL REF STD,
ENTER FWD SCAT VALUE
FORM: XXX.XX
- STEP 4.** Fit the grey foam plugs supplied with the calibration kit against all windows.

STEP 5. Enter the forward scatter calibration value from the calibration plaque.

STEP 6. The sensor will reply:
CALIBRATION IN PROGRESS

After 2 minutes the sensor will reply:
REMOVE OPTICS BLOCKS,
ENTER "OK"

STEP 7. Remove grey foam plugs from all windows and send text: OK.
The sensor will reply:
CALIBRATION CONTINUES

STEP 8. After 2 minute the sensor will reply:
CALIBRATION COMPLETE
REMOVE REF STD

STEP 9. Perform a Calibration Check. If the Calibration Check fails carefully repeat calibration. If the values continue to be outside of the limits contact Senseca UK.

8 VISIBILITY

8.1 Visibility Measurements

The visibility measurement capabilities of the sensor are summarised in section 9.1 **Error! Reference source not found.** Determination of visual range is based on measurements of the atmospheric extinction coefficient (EXCO). Note that EXCO includes the attenuating effects of both suspended particles and precipitating particles. Meteorological optical range (MOR) is determined by application of the standard relation:

$$\text{MOR} = 3.00/\text{EXCO}$$

9 SENSOR SPECIFICATIONS

The specifications of the RWS-30 sensor are summarised in the following pages.

9.1 Visibility Measurement

Function	Details
Measurement Range – MOR (Meteorological Optical Range) (User Configurable)	200m to 99.99km
Measurement Accuracy	MOR ~ 10km Better than $\pm 10\%$ MOR ~ 20km Better than $\pm 15\%$ MOR ~ 30km Better than $\pm 20\%$
Measurement Time Constant (User Configurable)	10 – 300 seconds (default 60 seconds)

Table 14 Visibility Measurement

Stability of MOR Zero Setting

Function	Details
Ambient Temperature Effects	$\leq 0.02/\text{km}$
Long Term Drift	$\leq 0.02/\text{km}$

Table 15 Zero Stability

9.2 Sensor Characteristics

9.2.1 Sample Volume

Function	Details
Scattering Angle	45° with $\pm 6^\circ$ cone angle
Sample Volume	400 cm ³

Table 16 Sample Volume

9.2.2 Light Source

Function	Details
Type	IRED
Central Wavelength	0.85 μ m
Bandwidth	0.04 μ m
Lifetime	>10 years
Modulation Frequency	2,000 Hz

Table 17 Light Source

9.2.3 Photodiode Detector

Function	Details
Type (Photovoltaic)	Silicon
Filter Bandwidth	0.08 μ m at 0.85 μ m

Table 18 Photodiode Detector Characteristics

9.2.4 Temperature Sensor

Function	Details
Type	Circuit mounted IC
Range	-40°C to 60°C

Table 19 Temperature Sensor Characteristics

9.3 Power Requirements

Function	Details
Power Source Sensor (Voltage)	9V to 36V DC (24V typical)
Power Source Sensor (Power)	3.5W
Power Source Hood Heaters (Voltage)	24V DC / 24 V AC
Power Source Hood Heater	24W
Window Heaters Supplied from Sensor Power	1.7W

Table 20 Power Requirements

9.4 Environmental

Function	Details
Sensor Operating Temperature Range	-40°C to +60°C
Altitude	0 to 15,000 ft
Precipitation	All weather
Humidity	0 to 100%
Protection Rating	IP66/67
CE Certified	√
EMC Compliant	EN61326-1 2021
RoHS and WEE Compliant	√

Table 21 Environmental Specifications

9.5 Maintenance

Function	Details
Typical Calibration Check Interval	12 months.
Typical Clean Windows Interval	3 months.

Table 22 Maintenance

9.6 Digital Communication Interface

Primary Communication Protocol

Function	Details
Primary Serial Bus	RS232C (Full Duplex), RS422, RS485
Secondary Serial Bus	RS232C (Full Duplex)

Table 23 Communication Protocols

Communication Parameters:

Function	Details
Baud Rates (User selectable)	1200 Baud to 57K6 Baud
Data Bits	8
Parity	None
Stop Bits	1
Flow Control	None
Message Termination	<CR,LF>

Table 24 Communication Parameters

9.7 Analogue Outputs

Some options may only be available if purchased.

Function	Details
Voltage	0 to 10VDC Equivalent to 0 to MOR _{MAX} .
Voltage Output Maximum Load	10kΩ
Current (User Selectable)	4 to 20 mA. Equivalent to 0 to MOR _{MAX} 0 to 20 mA. Equivalent to 0 to MOR _{MAX}
Current Output Maximum Resistance	500Ω

Table 25 Analogue Outputs

9.8 Relay Outputs

These options are available only if purchased.

Each relay has a Common terminal and NC and NO terminals.

Function	Details
Fault	Normally energised. Releases on fault condition
Relay # 1	Normally de-energised. Settable for visibility range 0.10 km to MOR _{MAX} . Default - 1km.
Relay # 2	Normally de-energised. Settable for visibility range 0. 10 km to MOR _{MAX} . Default - 1km. OR Window contamination
Switching Voltage (Max)	220 Vdc, 250 Vac
Switching Current (Max)	2A (Resistive Load)
Switching Power (Max)	60 W, 125 VA
Contact Type	Silver alloy with gold alloy overlay

Table 26 Relay Specification

9.9 Physical Properties

The dimensions of the RWS-30 are shown below.

Function	Details
Weight	3.8Kg (4.3Kg including pole mounting kit)
Length	315mm
Width	811mm
Depth	330mm (includes pole mounting kit)

Table 27 RWS Physical Properties

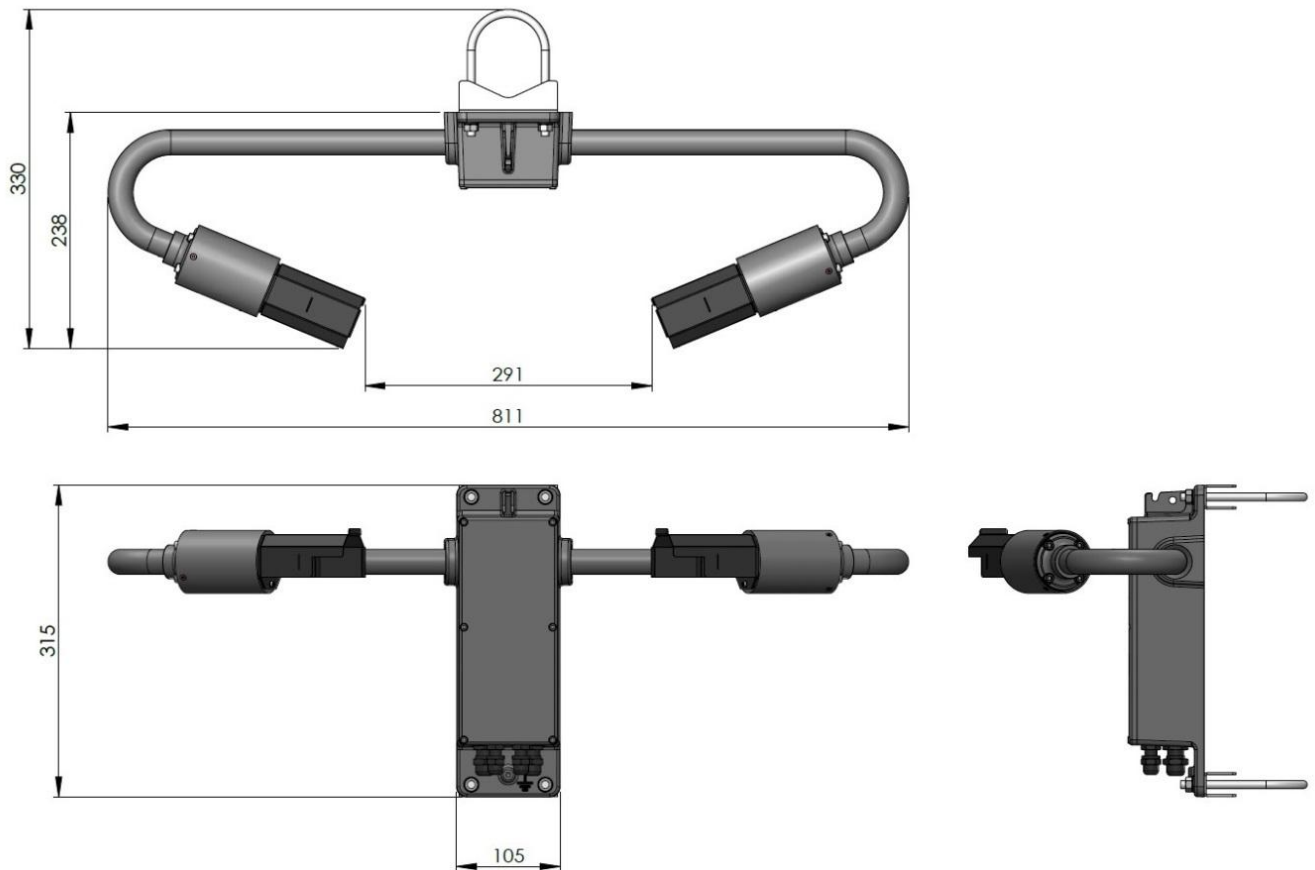

Figure 9-1 External Dimensions of RWS Sensors

10 INDEX

A

AFTER SALES SUPPORT	7
ANALOG DATA OUTPUT	65

C

CABLES	13
Cable Glands	13
Power and Signal Cables	9
Connecting	14
CALIBRATION	
Calibration Kit	9
Assembly	53
Re-calibration	57
CALIBRATION	52
CE CERTIFICATION - SAFETY	7
CHECKSUM	25, 45
LRC (RS485 only)	32, 33, 34
Normal (not RS485)	34
COMMUNICATION SPECIFICATION	63
CONFIGURATION OPTIONS	
Automatic Messages	35
Hood Heaters	41
Relays	37
Window Heaters	42
CONTACT DETAILS	8

D

DIMENSIONS OF SENSOR	66
----------------------------	----

E

ELECTRICAL CONNECTIONS	13
Power and Signal Cables	14
ENVIRONMENTAL SPECIFICATION	63

H

HEATERS	48
Hood Heaters	48
Commands	26
Connecting Power Supply	15
Window heaters (de-misters).....	48

I

IDENTIFICATION NUMBER.....	25, 27
INSTALLATION	
Height Above Ground.....	11
Mounting	12
Siting Considerations	10
INSTALLATION	10
IP RATING.....	63

M

MAINTENANCE	
General Checks	48
Hood Heaters.....	48
Window Cleaning	49
Self-Test Codes	49
MAINTENANCE	48
METEOROLOGICAL OPTICAL RANGE.....	25, 54, 57, 59
Calibration Check.....	53
Re-calibration	57
MOUNTING	SEE INSTALLATION

O

OPTIONAL ACCESSORIES	9
Calibration Kit.....	9
ORIENTATION OF SENSOR.....	11

P

PIN CONNECTIONS	14
Connections for RS232 or RS422.....	15
POWER REQUIREMENTS	62

R

RELAYS

Threshold levels	38
RS485.....	26

S

SELF-TEST CODES.....	49
SENSOR ORIENTATION.....	11
SENSOR SPECIFICATIONS	60

T

TROUBLESHOOTING	46
Self-Test Codes	49
TEST Command.....	46

V

VISIBILITY MEASUREMENTS.....	60
------------------------------	----

W

WARRANTY.....	7
WINDOW CLEANING.....	49
WINDOW HEATERS.....	48

NOTES

NOTES

WARRANTY

The manufacturer is required to respond to the "factory warranty" only in those cases provided by the Consumer Rights Act 2015. Each instrument is sold after rigorous inspections; if any manufacturing defect is found, it is necessary to contact the distributor where the instrument was purchased from. During the warranty period (12 months from the date of invoice) any manufacturing defects found will be repaired free of charge. Misuse, wear, neglect, lack or inefficient maintenance as well as theft and damage during transport are excluded. Warranty does not apply if changes, tampering or unauthorized repairs are made on the product.

The manufacturer repairs the products that show defects of construction in accordance with the terms and conditions of warranty included in the manual of the product.

TECHNICAL INFORMATION

The quality level of our instruments is the result of the continuous product development. This may lead to differences between the information reported in the manual and the instrument you have purchased. We reserve the right to change technical specifications and dimensions to fit the product requirements without prior notice.

DISPOSAL INFORMATION

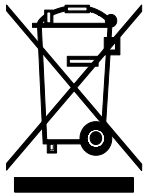

Electrical and electronic equipment marked with specific symbol in compliance with 2012/19/EU Directive must be disposed of separately from household waste. European users can hand them over to the dealer or to the manufacturer when purchasing a new electrical and electronic equipment, or to a WEEE collection point designated by local authorities. Illegal disposal is punished by law.

Disposing of electrical and electronic equipment separately from normal waste helps to preserve natural resources and allows materials to be recycled in an environmentally friendly way without risks to human health.



senseca.com



Senseca UK Ltd.
Unit 8 Harbour Road Trading Estate
Portishead, Bristol
BS20 7BL
UK
info.bristol@senseca.com

