



Meteorological Sensors
Visibly Better

ALS-2 Ambient Light Sensor Datasheet



*Measures Background Luminance
in accordance with FAA and ICAO
guidelines for use in Runway Visual
Range (RVR) applications*

*... direct connection to Biral visibility
and present weather sensors and field
calibration simplify system design and
reduce maintenance costs*

KEY FEATURES & BENEFITS

- Designed to FAA and ICAO requirements
- 0 to 40,000 Cdm-2 measurement range
- Choice of serial digital RS232 or RS422 digital outputs
- Simple and quick in field calibration
- Direct connection to Biral visibility and PW sensors
- Extensive self-test capabilities
- -60°C to 70°C operating range
- 2 Years Warranty

The ALS-2 Ambient Light Sensor is designed to measure background luminance as part of a Runway Visual Range system. Mounted alongside the runway, the ambient light sensor is often deployed with a visibility meter to provide the data necessary for calculation of RVR.

Designed to comply with specifications and guidelines produced by ICAO, WMO and the Federal Aviation Authority in the USA, the ALS-2 meets all the requirements for use in typical RVR systems. The ability to connect the sensor directly to a Biral visibility or present weather sensor and have the background luminance data incorporated into the visibility sensor data string simplifies system design and construction.

Available with a choice of serial data outputs the ALS-2 can be used to replace a wide range of background luminance meters in both legacy and new installations. The simple pole mounting system even incorporates an angular scale to ease installation.

A unique feature of the ALS-2 is its ability to be calibrated in the field without the need to disconnect the cable or send commands via the software interface. The ALS-2 Field Calibrator accessory simply fits over the hood and communicates with the sensor using an IR link through the optical window. The calibration can be checked and adjusted in a matter of minutes without the need for specialist staff or laboratory equipment.



Optional heated hood prevents snow accumulating around the optical window.

Designed to operate in the harshest of weather the ALS-2 has window heating and window contamination adjustment as standard. Extensive self-test capabilities and optional heating complete the package.



ALS-2 Calibrator connected to the ALS-2 for in situ calibration

SWS & VPF Series Sensor Configuration Information

For a detailed explanation of the configuration options please refer to the table opposite.

ALS2 - ALS-2 Ambient Light Sensor

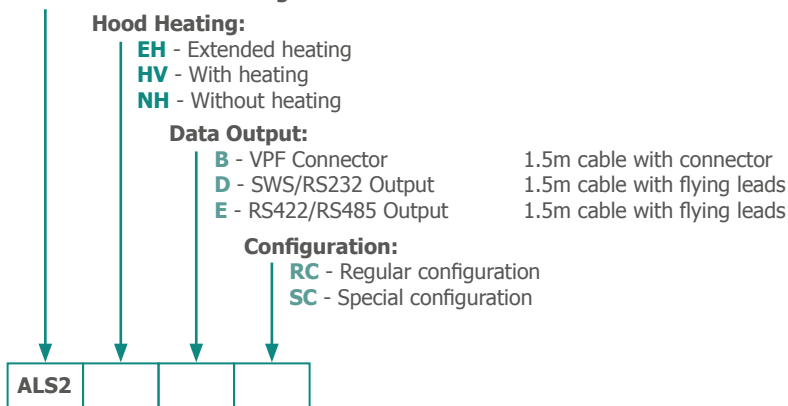

Example: ALS2.HV.D.RC (Please use this code when ordering your sensor).

SWS.LW Series Sensor Configuration Information

For a detailed explanation of the configuration options please refer to the table opposite.

ALS2 - ALS-2 Ambient Light Sensor

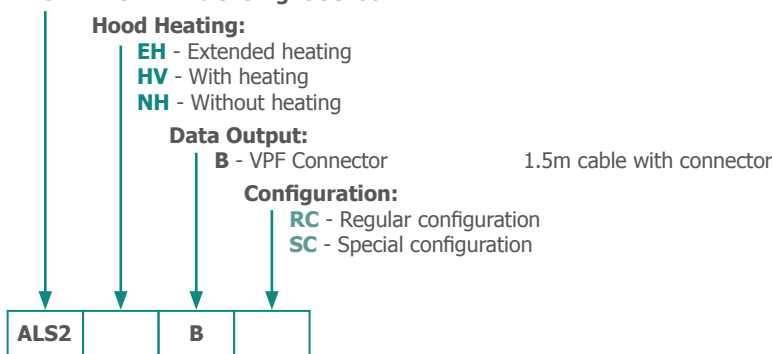

Example: ALS2.HV.B.RC (Please use this code when ordering your sensor).

Configuration Options Explained

Option	Description
Heating Options	<p>A heated hood is available to stop snow from accumulating around the optical window. The hood heating option is only required in regions where snow is experienced. Extended sensor heating allowing operation at -60°C is available; hood heating is included in this option.</p> <p>Option EH: Extended heating Option HV: Hood heating included Option NH: No hood heating</p>
Data Output	<p>There are three output options for the ALS-2.</p> <p>Option B: For direct connection to a VPF or SWS-LW sensor with ALS-2 option. 1.5m cable terminated with a circular connector.</p> <p>Option D: For either direct connection to a SWS sensor with ALS-2 option, or Serial RS232 output to a host system. Supplied with an unterminated 1.5m combined power and data cable.</p> <p>Option E: Serial RS422/RS485 output to a host system. Supplied with an unterminated 1.5m combined power and data cable.</p>
Configuration	<p>Reserved for customer specific configurations.</p> <p>Option RC: No customer specific configuration. Option SC: Special customer specific configuration.</p>

ALS-2

Ambient Light Sensor Specification



Ambient Light Measurement

Measures	Luminance (ambient light)
Output	Serial data. Optional analogue outputs
Measurement range:	0-40,000 cd m ⁻² (0.5-11,700 fL)
Resolution	1 cd m ⁻² (0.29 fL)
Measurement error	≤ 10% of value or 2 cd m ⁻² (0.58 fL), whichever is greatest
Spectral response	Wavelength sensitivity range 420-675 nm, peak 565 nm. Analogous to CIE luminous spectral efficiency.
Field of view	6°
Averaging period	60 s

Outputs

Serial data outputs	RS232, RS422 OR RS485
---------------------	-----------------------

Power Requirements

Sensor Power	9-36Vdc
Hood heating power	24Vac or dc
Sensor & window heater	2W
Hood heater	12W
Extended heating	18W (includes hood heater)

Additional Features

Window heater	Fitted as standard
Window contamination monitoring and compensation	Fitted as standard

Environmental

Operating temperature	-40°C to +70°C
With extended heating	-60°C to +70°C
Operating humidity	0 – 100% RH
Protection rating	IP66

Certification & Compliance

CE Certified
EMC compliance with EN61326-1997, 1998, 2001
RoHS and WEEE compliant

Physical

Material	Aluminium. Powder paint finish, with hard anodize base layer
Weight	1.5kg
Elevation angle range from horizontal	0° to 45°
Warranty	2 years
Lifetime	>10 years

Maintenance

Self-test capability	As standard
User confidence check	6 months recommended
Window Cleaning	Automatic compensation and warnings
Field calibration	With optional calibration kit

Included with Sensor

The sensor is delivered in sturdy recyclable foam filled packaging with:

- Pole mounting kit (1 x U-bolt and saddle)
- User manual and calibration certificates

Accessories – Optional

ALS-2.CAL	Ambient Light Sensor Calibrator
ALS2.WTY	1 Year Extended Warranty

Specifications are subject to review and change without notice. E&OE.

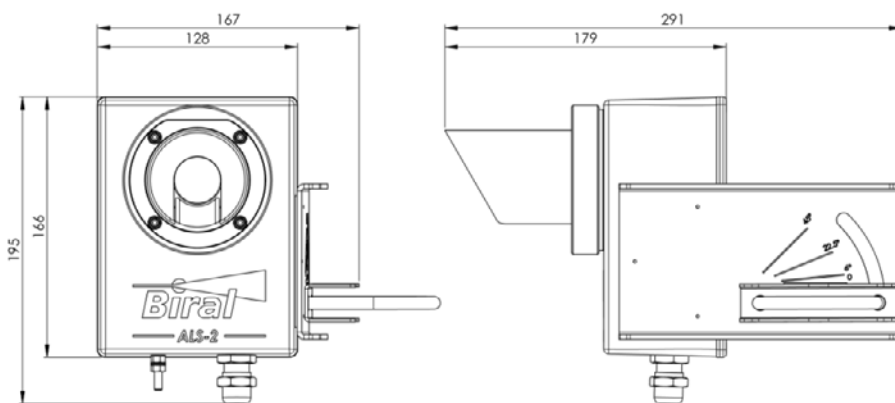

Dimensions in mm