

Instruction for Use

021531/11/09

Wind Transmitter

- with frequency output

4.3303.xx.xxx



ADOLF THIES GmbH & Co. KG

Hauptstraße 76

Box 3536 + 3541

Phone +49 551 79001-0

www.thiesclima.com

37083 Göttingen Germany

37025 Göttingen

Fax +49 551 79001-65

info@thiesclima.com

Safety Instructions

- Before operating with or at the device/product, read through the operating instructions. This manual contains instructions which should be followed on mounting, start-up, and operation. A non-observance might cause:
 - failure of important functions
 - Endangering of persons by electrical or mechanical effect
 - Damage to objects
- Mounting, electrical connection and wiring of the device/product must be carried out only by a qualified technician who is familiar with and observes the engineering regulations, provisions and standards applicable in each case.
- Repairs and maintenance may only be carried out by trained staff or **Adolf Thies GmbH & Co. KG**. Only components and spare parts supplied and/or recommended by **Adolf Thies GmbH & Co. KG** should be used for repairs.
- Electrical devices/products must be mounted and wired only in voltage-free state.
- **Adolf Thies GmbH & Co KG** guarantees proper functioning of the device/products provided that no modifications have been made to the mechanics, electronics or software, and that the following points are observed:
- All information, warnings and instructions for use included in these operating instructions must be taken into account and observed as this is essential to ensure trouble-free operation and a safe condition of the measuring system / device / product.
- The device / product is designed for a specific application as described in these operating instructions.
- The device / product should be operated with the accessories and consumables supplied and/or recommended by **Adolf Thies GmbH & Co KG** .
- Recommendation: As it is possible that each measuring system / device / product under certain conditions, and in rare cases, may also output erroneous measuring values, it is recommended using redundant systems with plausibility checks with **security-relevant applications**.

Environment

- As a longstanding manufacturer of sensors Adolf Thies GmbH & Co KG is committed to the objectives of environmental protection and is therefore willing to take back all supplied products governed by the provisions of "*ElektroG*" (German Electrical and Electronic Equipment Act) and to perform environmentally compatible disposal and recycling. We are prepared to take back all Thies products concerned free of charge if returned to Thies by our customers carriage-paid.
- Make sure you retain packaging for storage or transport of products. Should packaging however no longer be required, arrange for recycling as the packaging materials are designed to be recycled.



Documentation

- © Copyright **Adolf Thies GmbH & Co KG**, Göttingen / Germany
- Although this operating instruction has been drawn up with due care, **Adolf Thies GmbH & Co KG** can accept no liability whatsoever for any technical and typographical errors or omissions in this document that might remain.
- We can accept no liability whatsoever for any losses arising from the information contained in this document.
- Subject to modification in terms of content.
- The device / product should not be passed on without the/these operating instructions.

Contents

1	Models	4
2	Application	4
3	Construction and Mode of Operation	5
4	Recommendation Site Selection / Standard Installation	5
5	Installation.....	5
5.1	Mounting of the cup star.....	6
5.2	Electric Mounting.....	6
5.3	Mechanical Mounting	7
6	Maintenance	7
7	Connecting Diagrams	8
8	Technical Data.....	9
9	Dimensional Drawing.....	13
10	EC-Declaration of Conformity.....	14

1 Models

Order-No.	Measuring range	Electrical Output	Heating	Connection	Model
4.3303.10.000	0,3...50 m/s	3... 1042 Hz (with Offset)	w/o	5 pole plug	Standard
4.3303.10.007	0,3...50 m/s	3... 1042 Hz (w/o Offset)	w/o	7 pole plug	Standard
4.3303.22.000	0,3...50 m/s	3... 1042 Hz (with Offset)	24V / 20W	5 pole plug	Standard
4.3303.22.001	0,5...50 m/s	3... 1042 Hz (with Offset)	24V / 29W	5 pole plug	with reinforced cup star
4.3303.22.007	0,3...50 m/s	3... 1042 Hz (w/o Offset)	24V / 20W	7 pole plug	Standard
4.3303.22.007D	0,3...50 m/s	3... 1042 Hz (w/o Offset)	24V / 20W	7 pole plug	Cup star with tapered seam
4.3303.22.008	0,5...75 m/s	0... 754 Hz (with Offset)	24V / 20W	5 pole plug	with reinforced cup star
4.3303.22.018	0,5...75 m/s	0... 754 Hz (w/o Offset)	24V / 20W	5 pole plug	with reinforced cup star
4.3303.22.101	0,5...50 m/s	3... 1042 Hz (with Offset)	24V / 20W	5 pole plug	Ship model: - reinforced cup star, - special ball bearings
4.3303.22.600	0,3...60 m/s	3... 1251 Hz (with Offset)	24V / 20W	5 pole plug	Standard
4.3303.22.707	0,3...75 m/s	3... 1490 Hz (w/o Offset)	24V / 20W	7 pole plug	with reinforced cup star

- with offset = live zero / w/o Offset = no live zero

2 Application

The wind transmitter is used for the registration of the horizontal component of the wind velocity. The measuring value will be placed at the output as digital signal (frequency). The signal can be given to display instruments, recording instruments, datalogger as well as process control systems.

For winter operation, the instrument is equipped with an electronically regulated heating system in order to guarantee a smooth running of the ball bearings and to avoid ice-formation at the shaft and slot.

Power supply unit, Order no. 9.3388.00.000 provides the transmitter and the heating system with current.

It is advisable to attach Lightning rod, Order no. 4.3100.99.000 in areas with considerable lightning activity.

3 Construction and Mode of Operation

A low-inertia cup star (in ball bearings) made of aluminium, is set into rotation by the wind. The rotation is scanned opto-electronically, is converted into a square wave signal and output. The frequency of this signal is proportional to the number of rotations.

The output amplitude ranges between the maximum output voltage (15 V) and the ground (*w/o offset resp. no live-zero*) or a potential (*with offset resp. life-zero*), which is raised by approx. 1 V, see chapter 8 Technical Data.

The supply of the electronics can be done by DC-voltage of 4 V up to 42 V at a very low current consumption. An AC- or DC-voltage of 24 V is intended for the separate supply of the optional heating.. The heating prevents the wind transmitter from blocking under meteorological icing conditions.

The outer parts of the instrument are made of corrosion-resistant anodised aluminium. Labyrinth gaskets and O-rings protect the sensitive parts inside the instrument against humidity and dust.

The instrument is mounted onto a mast tube; the electrical plug-connection is located in the transmitter shaft.

The following parts are included in delivery: 1 Case
1 Cup star
1 Connection plug

4 Recommendation Site Selection / Standard Installation

According to international regulations, the surface wind should be measured at a height of 10 m above flat, open terrain, in order to achieve comparable values. An open terrain is defined as terrain where the distance between the wind-measuring instrument and the next obstacle is at least ten times the height of this obstacle (see VDI 3786, Part 2). If the regulation cannot be adhered to, the measuring instrument should be installed at a height at which the measurement values are not influenced by any local obstacles. In any case, the measuring instruments are to be installed at a height of 6 to 10 m above the mean height of the buildings or trees in the vicinity. If it is necessary to install the instrument on a roof, it should be installed in the centre of the roof in order to avoid any preferential directions.

5 Installation

Attention:

Storing, mounting and operation under weather conditions is permissible only in vertical position, as otherwise water can get into the instrument..

Remark:

When using fastening adapters (angle, traverses, etc.) please take a possible effect by turbulences into consideration.

5.1 Mounting of the cup star

Unscrew the cap nut (SW 8) from the wind velocity sensor case and remove the disk. Keep the rubber sealing washer in the protection cap. Set the cup star into position in such a way that the dowel pin in the cup star catches in the nut of the protective cap. Replace the disk and re-screw the cap nut. Hold the transmitter on the protective cap not on the cup.

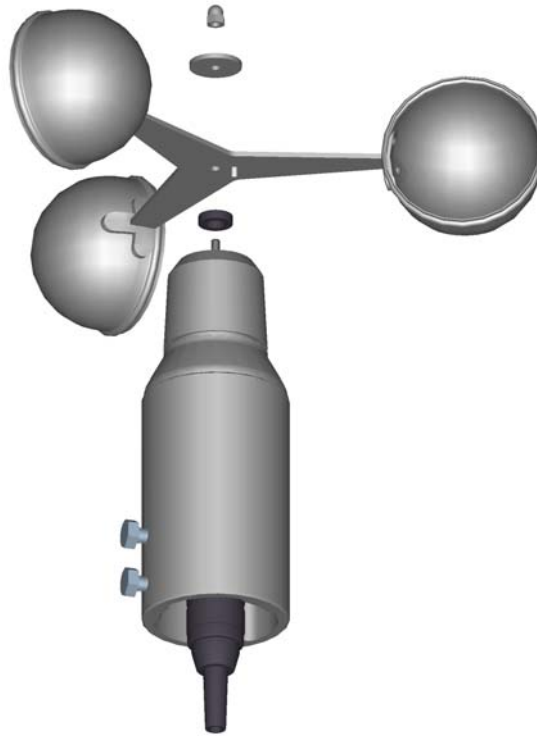

5.2 Electric Mounting

A shielded cable with a diameter of 5..8 mm and a core section of 0,5...0,75 mm² must be soldered on to the enclosed plug.

- The number of required cores, and the PIN assignment is stated in the connection diagram (chapter 8)..

Cable recommendation	
Type/ No. of cores /Diameter	Cable diameter
LIYCY 3 x 0,5 mm ²	ca. 5 mm
LIYCY 5 x 0,5 mm ²	ca. 7 mm

Coupling socket 201061 (7pole), type Binder, series 691

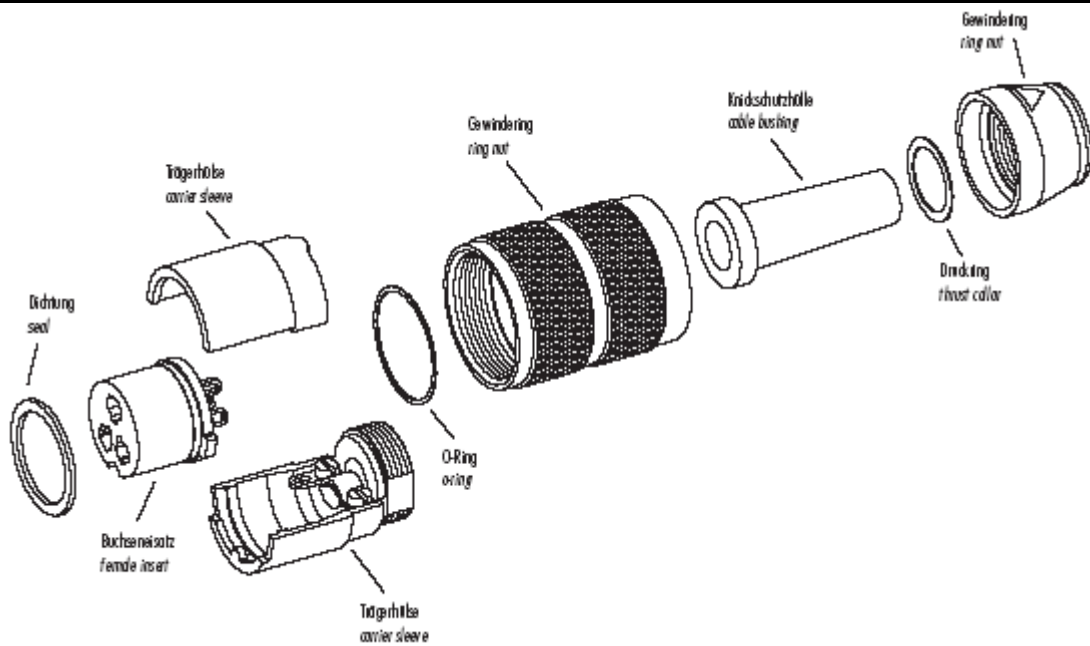

1. Removing Coupling socket
2. Stringing coupling socket on cable
3. Cutting cable sheath and shield 20 mm
4. Putting uncovered shield backwards onto the cable sheath
5. Stripping uncovered cable cores 5 mm
6. Pushing shrink hose over cable cores
7. Soldering stripped cable cores onto the solder flag, pushing shrink hose over the soldering afterwards, and shrinking it.
8. Fastening cable in the carrier sleeve by means of the clamp.
9. Mount coupling socket

5.3 Mechanical Mounting

Mount the transmitter to a short piece of pipe of R 1½" (Ø 48 mm) and a length of 50 mm. The short piece of pipe must have an internal diameter of at least 36 mm as the wind transmitter must be connected electrically with a plug from below. Once the electrical connection has been carried out, set the wind transmitter onto the short piece and fasten it to the shaft with the two hexagonal screws.

6 Maintenance

If properly installed, the instrument requires no maintenance. Heavy pollution can lead to blockage of the slot between the rotating and the stable parts of the transmitter. Thus it is advisable to remove the accumulated dirt from the instrument.

Remark:

Please use only original packing for transporting the instrument.

7 Connecting Diagrams

Order-no.	output signal
4.3303.10.000*	3... 1042 Hz = 0,3... 50 m/s
4.3303.22.000	3... 1042 Hz = 0,3... 50 m/s
4.3303.22.600	3... 1251 Hz = 0,3... 60 m/s
4.3303.22.001	5... 1251 Hz = 0,5... 75 m/s
4.3303.22.101	5... 1251 Hz = 0,5... 75 m/s
4.3303.22.008	3... 754 Hz = 0,5... 75 m/s
4.3303.22.018	3... 754 Hz = 0,5... 75 m/s

* Instrument without heating, pins 4 + 5 are not connected

Order-no.	PIN	Name	Function	View on the soldered side of the coupling socket
4.3303.10.000*	1	+U _B	supply 4... 42 V DC	
4.3303.22.000	2	GND	ground	
4.3303.22.600	3	SIG	output signal (frequency)	
4.3303.22.001**	4	HZ	heating supply: voltage: 24 V AC/DC power: 20 (29**)W	
4.3303.22.101	5			
4.3303.22.008				
4.3303.22.018				

* Instrument without heating, pins 4 + 5 are not connected

** Heating power: 29 W

Order-no.	Output signal
4.3303.10.007*	3... 1042 Hz = 0,3... 50 m/s
4.3303.22.007	3... 1042 Hz = 0,3... 50 m/s
4.3303.22.007D	3... 1042 Hz = 0,3... 50 m/s
4.3303.22.707	5... 1490 Hz = 0,3... 75 m/s

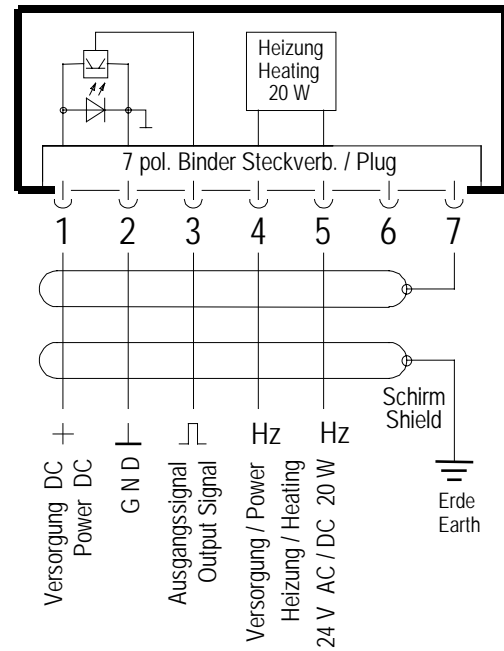

* Instrument without heating, pins 4 + 5 are not connected

Order-no.	PIN	Name	Function	View on the soldered side of the coupling socket
4.3303.10.007*	1	+U _B	supply 4... 42 V DC	
4.3303.22.007	2	GND	ground	
4.3303.22.007D	3	SIG	Output signal (frequency)	
4.3303.22.707	4	HZ	Heating supply: voltage: 24 V AC/DC power: 20 W	
	5			
	6	NC	Not connected	
	7	NC	Not connected	

* Instrument without heating, pins 4 + 5 are not connected

8 Technical Data

Remark:

For wind transmitters without heating the stated ambient temperature is possible only under ice-free conditions.

Order-no.	4.3303.10.000	4.3303.10.007	4.3303.22.000	4.3303.22.001
Measuring range	0,3 ... 50 m/s	0,3 ... 50 m/s	0,3 ... 50 m/s	0,5 ... 50 m/s
Starting velocity	0,3 m/s	0,3 m/s	0,3 m/s	0,5 m/s
Max. load	60 m/s	60 m/s	60 m/s	60 m/s
Accuracy	± 0,3 m/s resp. 2 % of measuring value	± 0,3 m/s resp. 2 % of measuring value	± 0,3 m/s resp. 2 % of measuring value	± 0,5 m/s resp. 2 % of measuring value
Electrical output				
Frequency	3... 1042 Hz (= 0,3... 50m/s)	3... 1042 Hz (= 0,3... 50m/s)	3...1042 Hz (= 0,3... 50m/s)	5... 1042 Hz (= 0,5... 50m/s)
Form	rectangle	rectangle	rectangle	rectangle
Amplitude	with offset	w/o offset	with offset	with offset
Output signal (U _L , U _H) unloaded	U _L ≈ 1 V U _H ≈ U _B U _H = max. 15 V DC	U _L ≈ 0 V U _H ≈ U _B U _H = max. 15 V DC	U _L ≈ 1 V U _H ≈ U _B U _H = max. 15 V DC	U _L ≈ 1 V U _H ≈ U _B U _H = max. 15 V DC
Output signal, loaded	< 5 mA	< 5 mA	< 5 mA	< 5 mA
Resolution	0,05 m wind run	0,05 m wind run	0,05 m wind run	0,05 m wind run
Wind load at 35 m/s	ca. 10N	ca. 10N	ca. 10N	ca. 10N
Distance constant	5 m	5 m	5 m	5 m
Ambient temperature	-40... +80°C *	-40... +80°C	-40... +80°C	-40...+80°C
Supply (U _B)				
Electronics current consumption, (unloaded)	4 ... 42V DC, < 0,5mA @ 5V	4 ... 42V DC, < 0,5mA @ 5V	4 ... 42V DC, < 0,5mA @ 5V	4 ... 42V DC, < 0,5mA @ 5V
Heating	Not applicable	Not applicable	24 V AC/DC, 20 W; electronically regulated	24 V AC/DC, 29 W; electronically regulated
Connection	5 pole plug connection	7 pole plug connection	5 pole plug connection	5 pole plug connection
Mounting	onto mast tube 1 ½", e.g. DIN 2441	onto mast tube 1 ½", e.g.. DIN 2441	onto mast tube 1 ½", e.g. DIN 2441	onto mast tube 1 ½", e.g. DIN 2441
Protection	IP 55	IP 55	IP 55	IP 55
Weight	1 kg	1 kg	1 kg	1 kg
Model	Standard	Standard	Standard	with reinforced cup star

Order-no.	4.3303.22.007	4.3303.22.007D	4.3303.22.008	4.3303.22.018
Measuring range	0,3 ... 50 m/s	0,3 ... 50 m/s	0,5 ... 75 m/s	0,5 ... 75 m/s
Starting velocity	0,3 m/s	0,3 m/s	0,5 m/s	0,5 m/s
Max. load	60 m/s	60 m/s	75 m/s, temporary	75 m/s, temporary
Accuracy	± 0,3 m/s resp. 2 % of measuring value	± 0,3 m/s resp. 2 % of measuring value	± 0,5 m/s resp. 2 % of measuring value	± 0,5 m/s resp. 2 % of measuring value
Electrical output				
Frequency	3... 1042 Hz (= 0,3... 50m/s)	3... 1042 Hz (= 0,3... 50m/s)	3... 754 Hz (= 0,5... 75 m/s)	3... 754 Hz (= 0,5... 75m/s)
Form	rectangle	rectangle	rectangle	rectangle
Amplitude	w/o offset	w/o offset	with offset	w/o offset
Output signal (U _L , U _H) unloaded	U _L ≈ 0 V U _H ≈ U _B U _H = max. 15 V DC	U _L ≈ 0 V U _H ≈ U _B U _H = max. 15 V DC	U _L ≈ 1 V U _H ≈ U _B U _H = max. 15 V DC	U _L ≈ 0 V U _H ≈ U _B U _H = max. 15 V DC
Output signal, loaded	< 5 mA	< 5 mA	< 5 mA	< 5 mA
Resolution	0,05 m wind run	0,05 m wind run	0,1 m wind run	0,1 m wind run
Wind load at 35 m/s	ca. 10N	ca. 10N	ca. 10N	ca. 10N
Distance constant	5 m	5 m	5 m	5 m
Ambient temperature	-40... +80°C	-40... +80°C	-40... +80°C	-40... +80°C
Supply (U _B)				
Electronics	4 ... 42V DC,	4 ... 42V DC,	4 ... 42V DC,	4 ... 42V DC,
current consumption, (unloaded)	< 0,5mA @ 5V	< 0,5mA @ 5V	< 0,5mA @ 5V	< 0,5mA @ 5V
Heating	24 V AC/DC, 20 W; electronically regulated	24 V AC/DC, 20 W; electronically regulated	24 V AC/DC, 20 W; electronically regulated	24 V AC/DC, 20 W; electronically regulated
Connection	7 pole plug connection	7 pole plug connection	5 pole plug connection	5 pole plug connection
Mounting	onto mast tube 1 ½", e.g. DIN 2441	onto mast tube 1 ½", e.g. DIN 2441	onto mast tube 1 ½", e.g. DIN 2441	onto mast tube 1 ½", e.g. DIN 2441
Protection	IP 55	IP 55	IP 55	IP 55
Weight	1 kg	1 kg	1 kg	1 kg
Model	Standard	Cup star with tapered seam	With reinforced cup star	With reinforced cup star

Order-no.	4.3303.22.101	4.3303.22.600	4.3303.22.707	
Measuring range	0,5 ... 50 m/s	0,3 ... 60 m/s	0,5 ... 75 m/s	
Starting velocity	>0,5 m/s	0,3 m/s	0,5 m/s	
Max. load	60 m/s	60 m/s	75 m/s, temporary	
Accuracy	± 0,5 m/s resp. 2 % of measuring value	± 0,3 m/s resp. 2 % of measuring value	± 0,5 m/s resp. 2 % of measuring value	
Electrical output				
Frequency	5... 1042 Hz (= 0,5... 50m/s)	3... 1251 Hz (= 0,3... 60m/s)	5... 1490 Hz (= 0,5... 75m/s)	
Form	rectangle	rectangle	rectangle	
Amplitude	with offset	with offset	w/o offset	
Output signal (U _L , U _H) unloaded	U _L ≈ 1 V U _H ≈ U _B U _H = max. 15 V DC	U _L ≈ 1 V U _H ≈ U _B U _H = max. 15 V DC	U _L ≈ 0 V U _H ≈ U _B U _H = max. 15 V DC	
Output signal, loaded	< 5 mA	< 5 mA	< 5 mA	
Resolution	0,05 m wind run	0,05 m wind run	0,05 m wind run	
Wind load at 35 m/s	ca. 10N	ca. 10N	ca. 10N	
Distance constant	5 m	5 m	5 m	
Ambient temperature	-40... +80°C	-40... +80°C	-40... +80°C	
Supply (U _B)				
Electronics	4 ... 42V DC,	4 ... 42V DC,	4 ... 42V DC,	
current consumption, (unloaded)	< 0,5mA @ 5V	< 0,5mA @ 5V	< 0,5mA @ 5V	
Heating	24 V AC/DC, 20 W; electronically regulated	24 V AC/DC, 20 W; electronically regulated	24 V AC/DC, 20 W; electronically regulated	
Connection	5 pole plug connection	5 pole plug connection	7 pole plug connection	
Mounting	onto mast tube 1 ½", e.g. DIN 2441	onto mast tube 1 ½", e.g. DIN 2441	onto mast tube 1 ½", e.g. DIN 2441	
Protection	IP 55	IP 55	IP 55	
Weight	1 kg	1 kg	1 kg	
Model	„ship model“ with: - reinforced cup star - special ball bearings	Standard	With reinforced cup star	

9 Dimensional Drawing

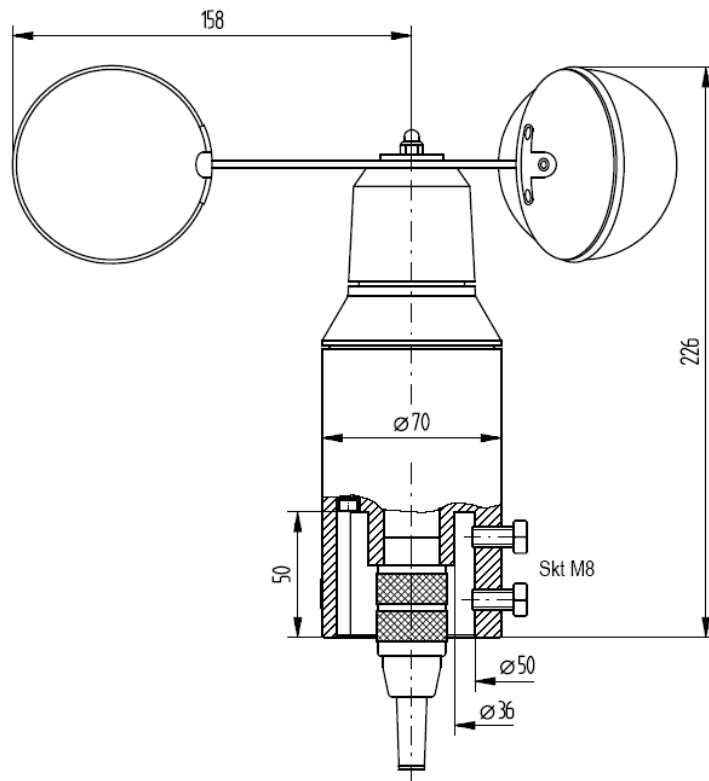

10 EC-Declaration of Conformity

Document-No.: 000433

Month: 06 Year: 08

Manufacturer: **ADOLF THIES GmbH & Co. KG**

Hauptstr. 76
D-37083 Göttingen
Tel.: (0551) 79001-0
Fax: (0551) 79001-65
email: Info@ThiesClima.com

Description of Product: **Wind Transmitter**

Article No.	4.3303.10.000	4.3303.10.007	4.3303.22.000	4.3303.22.001
	4.3303.22.007	4.3303.22.007D	4.3303.22.008	4.3303.22.018
	4.3303.22.101	4.3303.22.600	4.3303.22.707	

specified technical data in the document: **021530/03/07**

The indicated products correspond to the essential requirement of the following European Directives and Regulations:

- 2004/108/EC DIRECTIVE 2004/108/EC OF THE EUROPEAN PARLIAMENT AND OF THE COUNCIL of 15 December 2004 on the approximation of the laws of the Member States relating to electromagnetic compatibility and repealing Directive 89/336/EEC
- 2006/95/EC DIRECTIVE 2006/95/EC OF THE EUROPEAN PARLIAMENT AND OF THE COUNCIL of 12 December 2006 on the harmonisation of the laws of Member States relating to electrical equipment designed for use within certain voltage limits
- 552/2004/EC Regulation (EC) No 552/2004 of the European Parliament and the Council of 10 March 2004 on the interoperability of the European Air Traffic Management network (the interoperability Regulation)

The indicated products comply with the regulations of the directives. This is proved by the compliance with the following standards:

Reference number	Specification
IEC 61000-6-2: 2005	Electromagnetic compatibility Immunity for industrial environment
IEC 61000-6-3: 2006	Electromagnetic compatibility Emission standard for residential, commercial and light industrial environments
IEC 61010-1: 2001	Safety requirements for electrical equipment for measurement, control and laboratory use. Part 1: General requirements

Place: Göttingen

Date: 30.06.2008

Legally binding signature:

issuer:

.....
Wolfgang Behrens, General Manager

.....
Joachim Beinhorn, Development Manager

This declaration certifies the compliance with the mentioned directives, however does not include any warranty of characteristics. Please pay attention to the security advises of the provided instructions for use.



ADOLF THIES GmbH & Co. KG

Hauptstraße 76 37083 Göttingen Germany
P.O. Box 3536 + 3541 37025 Göttingen
Phone +49 551 79001-0 Fax +49 551 79001-65
www.thiesclima.com info@thiesclima.com



- Alterations reserved-