

Instruction for Use

021591/02/09

Combined Wind Transmitter

Output: 8 Bit parallel

4.3324.32.000 / 001



ADOLF THIES GmbH & Co. KG

Hauptstraße 76

Box 3536 + 3541

Phone +49 551 79001-0

www.thiesclima.com

37083 Göttingen Germany

37025 Göttingen

Fax +49 551 79001-65

info@thiesclima.com

Safety Instructions

- Before operating with or at the device/product, read through the operating instructions. This manual contains instructions which should be followed on mounting, start-up, and operation. A non-observance might cause:
 - failure of important functions
 - Endangering of persons by electrical or mechanical effect
 - Damage to objects
- Mounting, electrical connection and wiring of the device/product must be carried out only by a qualified technician who is familiar with and observes the engineering regulations, provisions and standards applicable in each case.
- Repairs and maintenance may only be carried out by trained staff or **Adolf Thies GmbH & Co. KG**. Only components and spare parts supplied and/or recommended by **Adolf Thies GmbH & Co. KG** should be used for repairs.
- Electrical devices/products must be mounted and wired only in voltage-free state.
- **Adolf Thies GmbH & Co KG** guarantees proper functioning of the device/products provided that no modifications have been made to the mechanics, electronics or software, and that the following points are observed:
 - All information, warnings and instructions for use included in these operating instructions must be taken into account and observed as this is essential to ensure trouble-free operation and a safe condition of the measuring system / device / product.
 - The device / product is designed for a specific application as described in these operating instructions.
 - The device / product should be operated with the accessories and consumables supplied and/or recommended by **Adolf Thies GmbH & Co KG** .
 - Recommendation: As it is possible that each measuring system / device / product under certain conditions, and in rare cases, may also output erroneous measuring values, it is recommended using redundant systems with plausibility checks with **security-relevant applications**.

Environment

- As a longstanding manufacturer of sensors Adolf Thies GmbH & Co KG is committed to the objectives of environmental protection and is therefore willing to take back all supplied products governed by the provisions of "*ElektroG*" (German Electrical and Electronic Equipment Act) and to perform environmentally compatible disposal and recycling. We are prepared to take back all Thies products concerned free of charge if returned to Thies by our customers carriage-paid.
- Make sure you retain packaging for storage or transport of products. Should packaging however no longer be required, arrange for recycling as the packaging materials are designed to be recycled.



Documentation

- © Copyright **Adolf Thies GmbH & Co KG**, Göttingen / Germany
- Although this operating instruction has been drawn up with due care, **Adolf Thies GmbH & Co KG** can accept no liability whatsoever for any technical and typographical errors or omissions in this document that might remain.
- We can accept no liability whatsoever for any losses arising from the information contained in this document.
- Subject to modification in terms of content.
- The device / product should not be passed on without the/these operating instructions.

Contents

1	Models available	4
2	Application	4
3	Construction and Mode of Operation	4
4	Recommendation Side Selection/ Standard Installation	5
5	Installation.....	6
5.1	Mounting of wind vane	6
5.2	Mounting of Cup Star	7
5.3	Mounting of Wind Transmitter	7
5.4	Electrical Mounting	8
6	Maintenance	8
7	Connecting Diagrams	8
8	Technical Data	9
9	Dimensional Drawings	10
10	EC-Declaration of Conformity.....	12

Figures

Figure 1:	Thies Code table for 8 bit parallel	5
Figure 2:	Dimension 4.3324.32.000	10
Figure 3:	Dimension 4.3324.32.001	11

1 Models available

Order-No.	Measuring range	Electrical Output	Model
4.3324.32.000	WV 0,3 ... 50 m/s WD 0 ... 360°	3 ... 1042 Hz (with Offset) 8 Bit parallel (with Offset)	Standard version
4.3324.32.001	WV 0,3 ... 50 m/s WD 0 ... 360°	3 ... 1042 Hz (with Offset) 8 Bit parallel (with Offset)	Ship version* (short wind vane, reinforced cup star, special ball bearing)

* Comb. Wind transmitters for heavy mechanical load, for ex. on ships, wind power plants or the like.

The combined wind transmitters are shipped in semi-mounted state, in order to avoid transport damages and to keep the package small.

The following parts are included in delivery:

- 1 x combined wind transmitter, pre-mounted
- 1 x cup star
- 1 x wind vane
- 1 x connecting plug
- 1 x Instruction

2 Application

The combined wind transmitter serves for the acquisition of the horizontal components of the wind speed and the wind direction. All measuring values are available at the outputs analogue signals. They can be output to THIES-display instruments, and systems or for further processing.

For winter operation the instruments are equipped with an electronically regulated heating in order to guarantee a smooth running of the ball bearings, and to avoid ice-formation at the slot of the outer rotation parts. The electrical supply of wind transmitter heating is carried out, for ex., by our power supply unit, order-no. 9.3388.00.000.

3 Construction and Mode of Operation

The housing, cup star and wind vane are made of aluminum, die the surfaces are anodized. The bow consists of stainless steel. Labyrinth seals and o-rings protect the sensitive internal parts from precipitation. The instrument is designed for mounting to a mast tube; the electrical plug connection is situated in the transmitter shaft.

A low-inertia light-metal cup star (in ball bearings) is set into rotation by the wind. A pulse frequency is available at the output through the opto-electronic revolution-scanning.

The wind direction is acquired by means of an inertia-free wind vane. The axis of the wind vane is running in ball bearings and carries a diametrically magnetized magnet at the inner end. The angle position of the axis is scanned contact-free by a TMR- Sensor (Tunnel Magneto Resistance) through the position of the magnet field. As signal this sensor outputs two cosine- and sinus-depending voltages.

A connected micro-controller calculates from these voltages the wind direction in 144 sectors (2.5° / sector). Related to sector 1 is the wind direction 0° – 2,5°, sector 144 corresponds to the wind direction 357.5°- 360°.

Sector	Gray-Code	Angle degree	Sector	Gray-Code	Angle degree	Sector	Gray-Code	Angle degree	Sector	Gray-Code	Angle degree	Sector	Gray-Code	Angle degree	Sector	Gray-Code	Angle degree
1	0	0,0	25	20	60,0	49	40	120,0	73	228	180,0	97	184	240,0	121	156	300,0
2	1	2,5	26	21	62,5	50	41	122,5	74	229	182,5	98	185	242,5	122	157	302,5
3	3	5,0	27	23	65,0	51	43	125,0	75	231	185,0	99	187	245,0	123	159	305,0
4	2	7,5	28	22	67,5	52	42	127,5	76	230	187,5	100	186	247,5	124	158	307,5
5	6	10,0	29	18	70,0	53	46	130,0	77	226	190,0	101	190	250,0	125	154	310,0
6	7	12,5	30	19	72,5	54	47	132,5	78	227	192,5	102	191	252,5	126	155	312,5
7	5	15,0	31	17	75,0	55	45	135,0	79	225	195,0	103	189	255,0	127	153	315,0
8	4	17,5	32	16	77,5	56	44	137,5	80	224	197,5	104	188	257,5	128	152	317,5
9	12	20,0	33	48	80,0	57	36	140,0	81	160	200,0	105	180	260,0	129	136	320,0
10	13	22,5	34	49	82,5	58	37	142,5	82	161	202,5	106	181	262,5	130	137	322,5
11	15	25,0	35	51	85,0	59	39	145,0	83	163	205,0	107	183	265,0	131	139	325,0
12	14	27,5	36	50	87,5	60	38	147,5	84	162	207,5	108	182	267,5	132	138	327,5
13	10	30,0	37	54	90,0	61	34	150,0	85	166	210,0	109	178	270,0	133	142	330,0
14	11	32,5	38	55	92,5	62	35	152,5	86	167	212,5	110	179	272,5	134	143	332,5
15	9	35,0	39	53	95,0	63	33	155,0	87	165	215,0	111	177	275,0	135	141	335,0
16	8	37,5	40	52	97,5	64	32	157,5	88	164	217,5	112	176	277,5	136	140	337,5
17	24	40,0	41	60	100,0	65	96	160,0	89	172	220,0	113	144	280,0	137	132	340,0
18	25	42,5	42	61	102,5	66	97	162,5	90	173	222,5	114	145	282,5	138	133	342,5
19	27	45,0	43	63	105,0	67	99	165,0	91	175	225,0	115	147	285,0	139	135	345,0
20	26	47,5	44	62	107,5	68	98	167,5	92	174	227,5	116	146	287,5	140	134	347,5
21	30	50,0	45	58	110,0	69	102	170,0	93	170	230,0	117	150	290,0	141	130	350,0
22	31	52,5	46	59	112,5	70	103	172,5	94	171	232,5	118	151	292,5	142	131	352,5
23	29	55,0	47	57	115,0	71	101	175,0	95	169	235,0	119	149	295,0	143	129	355,0
24	28	57,5	48	56	117,5	72	100	177,5	96	168	237,5	120	148	297,5	144	128	357,5

Figure 1: Thies Code table for 8 bit parallel

4 Recommendation Side Selection/ Standard Installation

In general wind measurement instruments should be able to detect the wind conditions of a large area. In order to obtain comparable values when determining the surface wind, measurements should be taken at a height of 10 meters over an even unobstructed area. An unobstructed area means that the distance between the wind transmitter and an obstacle should be at least 10 times the height of the obstacle (s. VDI 3786). If it is not possible to fulfil this condition, then the wind transmitter should be set up a height where local obstacles do not influence the measured values to any significant extent (approx. 6 - 10 m above the obstacle).

The wind transmitter should be set up in the centre of flat roofs and not on the roof side in order to avoid bias in the direction (privileged directions).

5 Installation

Attention:

Storing, mounting and operation under weather conditions is permissible only in vertical position, as otherwise water can get into the instrument.

Remark:

When using fastening adapters (angle, traverses, hangers etc.) please take a possible effect by turbulences into consideration.

Remark:

It is advisable to attach lightning rod, order no. **4.3100.99.000** in areas with considerable lightning activity.

5.1 Mounting of wind vane

Tools

- Screw wrench SW 8

Mounting of wind vane

1. Remove wind transmitter housing and wind vane from the packing.
2. Screw off cap nut (SW 8) The gasket remains in the protective cap
2. Mounting of wind vane acc. to figure. The dowel at the wind vane must catch the notch of the protective cap. The cap nut is to be screwed tightly.

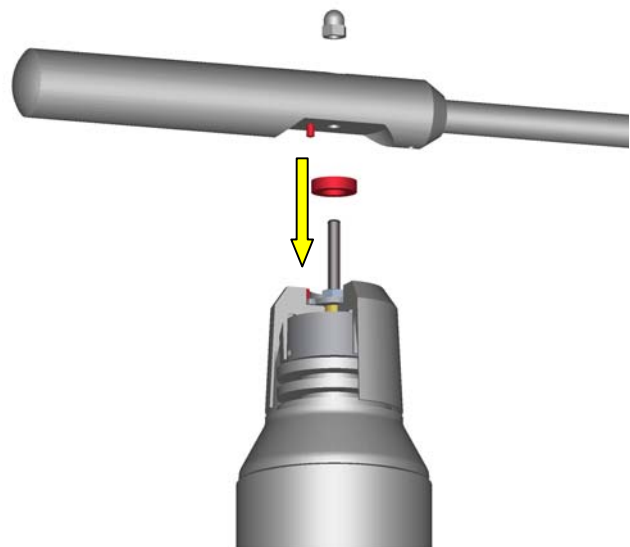

5.2 Mounting of Cup Star

Tools

- Screw wrench SW 8

Mounting

1. Remove cup star from the packing.
2. Screw-off cap nut (SW 8) and remove disc..
The gasket remains in the protective cap.
1. Mounting of cup star acc. to figure.
The dowel at the cup star cross must catch the notch of the protective cap. The cap nut is to be screwed tightly.

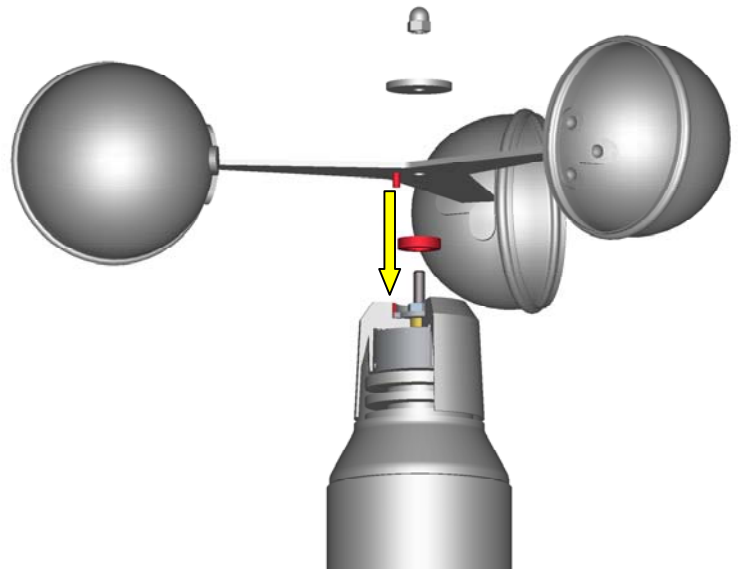

5.3 Mounting of Wind Transmitter

The transmitter can be mounted onto a tube of R 1 1/2" (\varnothing 48,3 mm), 50 mm long. The internal diameter of the mounting tube must be at least 40 mm since the transmitter will be plugged into an electrical system from below. Solder a cable (for ex. LiYCY) with the required number of leads of each 0,5 mm² onto the enclosed plug. After electrical connection, set the wind transmitter onto the tube. North marking and bow shall indicate to the North.

North Alignment

Rotate the case markings (north marking) on the shaft and on the protective cap until they are aligned. Then select an obvious point in a northerly direction in the surroundings (a tree, a building etc.) with the aid of a compass. Take a bearing on this point over the wind vane and the counter weight of the wind direction transmitter, and when these coincide screw the wind transmitter into place. (the north marking must indicate to the *geographic north*).

The instrument is fixed on the shaft by means of the two hexagon head screws.

Alignment of the comb. Wind Transmitter on a Ship

- The reference point for the wind transmitter is the roll-axis of the ship, whereat "0°" is related to the **ship bow**.

Rotate the case markings (north marking) on the shaft and on the protective cap until they are aligned. Take a bearing on ship bow over the wind vane and the counter weight of the wind direction transmitter, and when these coincide screw the wind transmitter into place. (the north marking must indicate to the geographic north).

- When aligning the comb. wind transmitter on other mobile objects (for ex. vehicles, wind power plants etc.) this procedure can be adopted

5.4 Electrical Mounting

For electrical connection please refer to the connecting diagram.

6 Maintenance

After proper mounting the instrument works maintenance free.

Heavy pollution can clog up the slit between the rotating and the stationary parts of the wind transmitter. This slit must be kept clean.

Remark:

Please use only original packing for transporting the instrument.

7 Connecting Diagrams

Remark:

- The cable shield should be connected on both sides (to the plug of the wind transmitter and to the data logging) in case the data logging or the like is on the same electrical potential.
- The cable shield should be connected on one side (only to the data logging) in case there are potential differences between wind transmitter and data logging.

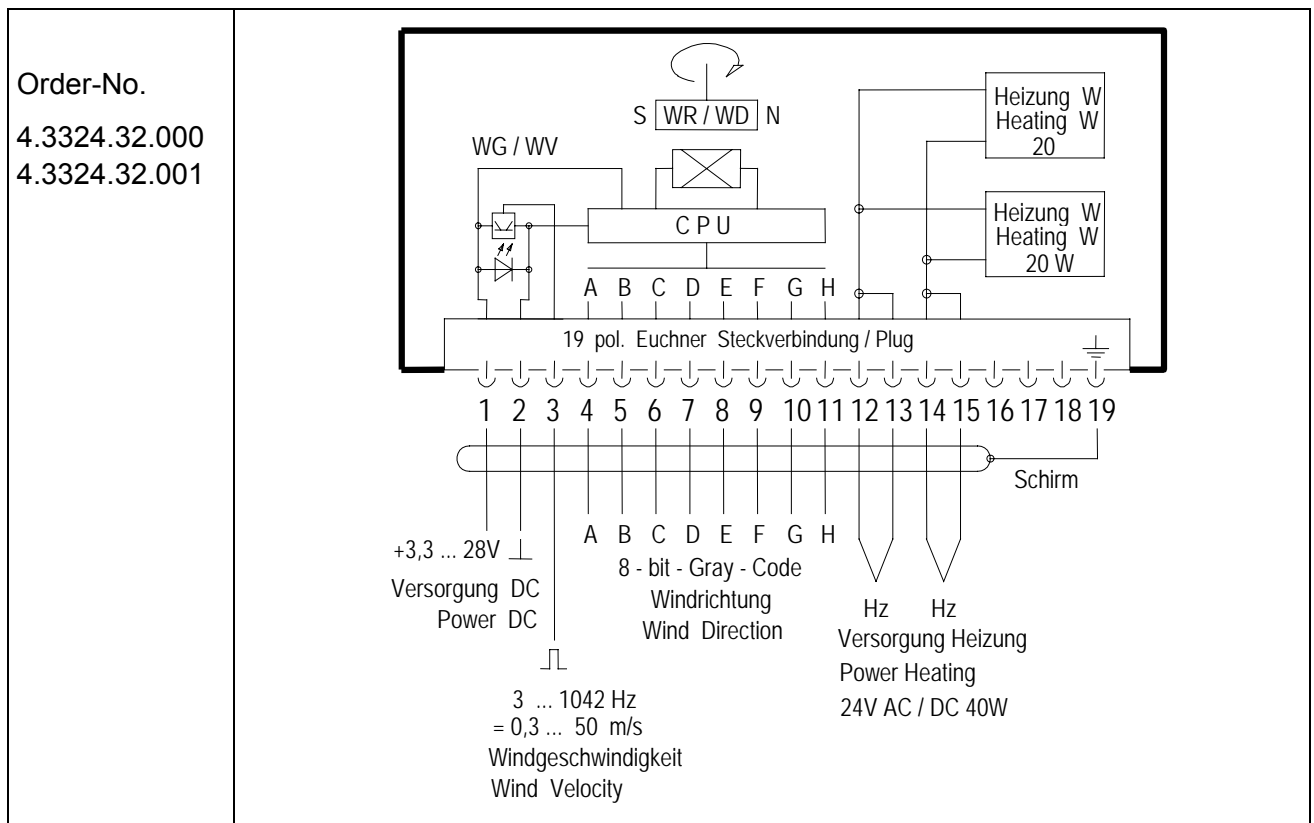

8 Technical Data

	Wind Speed	Wind Direction
Measuring range	0,3 ... 50 m/s	0 ... 360°
Start-up (with 4.3324.32.000)	0,3 m/s	<0,6 m/s at 90° vane move
Start-up (with 4.3324.32.001)	0,3 m/s	<1 m/s at 90° vane move
Accuracy	±0,3 m/s resp. 2 % of meas. value	±1,5°
Resolution	0,05 m wind run	2,5°
Distance constant	5 m	-----
Damping ratio (acc. to ASTM D 5366-96) with 4.3324.32.000	-----	D > 0,3
Electr. output	3 ... 1042 Hz	8 bit parallel (Code)
Voltage supply (U _B)	3,3...28 V DC	3,3...28 V DC
Output signal, unloaded	U _{Low} ≈ 1 V / U _{Height} ≈ U _B	U _{Low} ≈ 0.7V / U _{Height} ≈ U _B
Output signal, loaded	< 5 mA	< 10 mA
Current consumption (unloaded)	< 2.5 mA (U _B = 15 V)	< 2 mA (U _B = 15 V)
Max. wind load	60 m/s	
Heating	24 V DC/AC, approx. 40 W, electronically regulated	
Ambient temperature	-35...+80°C	
Protection	IP 55	
Wind load at 35 m/s	approx. 50 N	
Mounting	onto mast tube 1 ½", for ex. DIN 2441	
Connection	19-pole plug connection in the shaft	
Weight	2,8 kg	

9 Dimensional Drawings

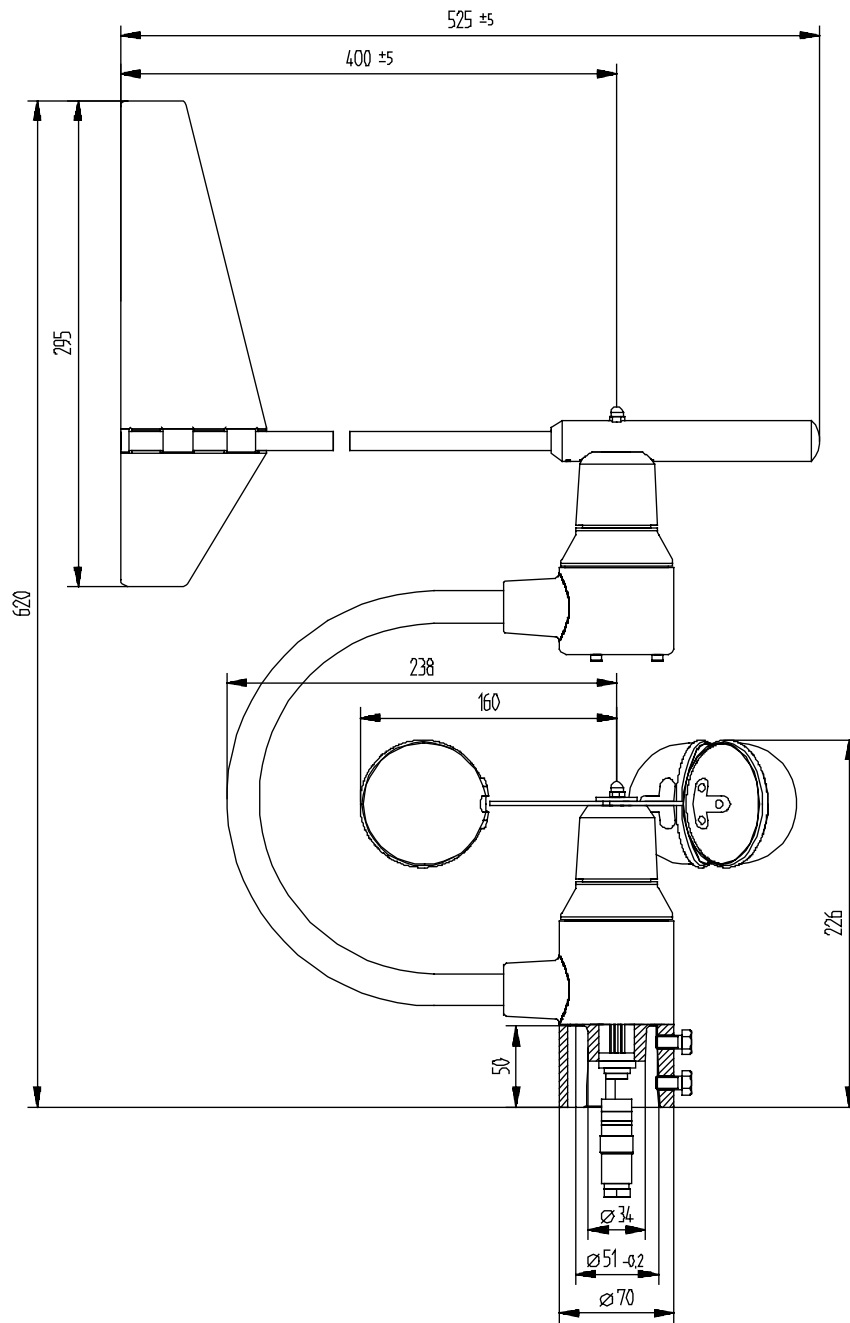

Figure 2: Dimension 4.3324.32.000

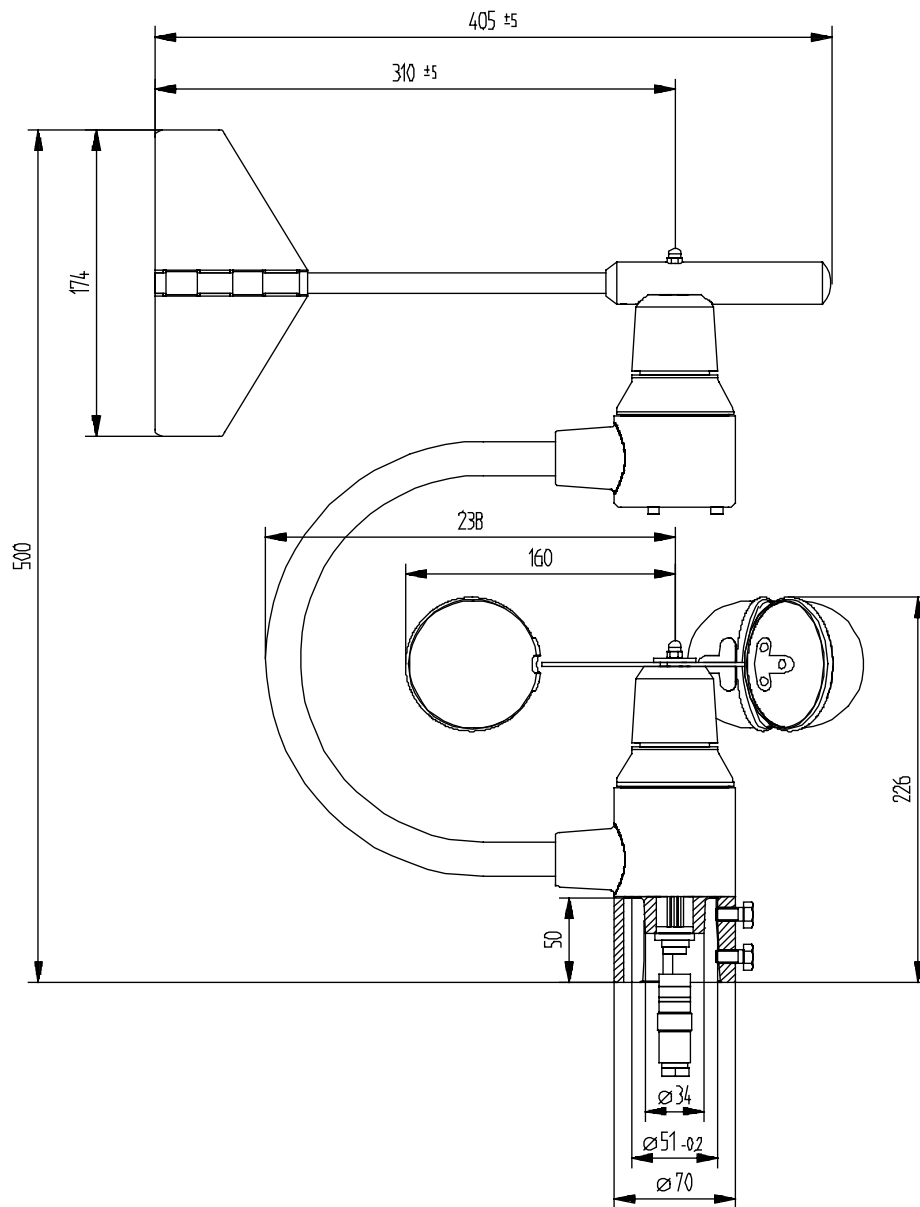

Figure 3: Dimension 4.3324.32.001

10 EC-Declaration of Conformity

Document-No.: **000439**

Month: 02 Year: 09

Manufacturer: **ADOLF THIES GmbH & Co. KG**

Hauptstr. 76
D-37083 Göttingen
Tel.: (0551) 79001-0
Fax: (0551) 79001-65
email: Info@ThiesClima.com

Description of Product: **Combined Wind Transmitter**

Article No.	4.3324.32.000	4.3324.32.001	4.3324.32.900	
	4.3336.22.000	4.3336.22.001	4.3336.22.008	4.3336.32.000
	4.3336.32.001	4.3336.32.008		

specified technical data in the document: **021590/02/09; 021593/02/09; 021594/02/09;**

The indicated products correspond to the essential requirement of the following European Directives and Regulations:

2004/108/EC	DIRECTIVE 2004/108/EC OF THE EUROPEAN PARLIAMENT AND OF THE COUNCIL of 15 December 2004 on the approximation of the laws of the Member States relating to electromagnetic compatibility and repealing Directive 89/336/EEC
2006/95/EC	DIRECTIVE 2006/95/EC OF THE EUROPEAN PARLIAMENT AND OF THE COUNCIL of 12 December 2006 on the harmonisation of the laws of Member States relating to electrical equipment designed for use within certain voltage limits
552/2004/EC	Regulation (EC) No 552/2004 of the European Parliament and the Council of 10 March 2004 on the interoperability of the European Air Traffic Management network (the interoperability Regulation)

The indicated products comply with the regulations of the directives. This is proved by the compliance with the following standards:

Reference number	Specification
IEC 61000-6-2: 2005	Electromagnetic compatibility Immunity for industrial environment
IEC 61000-6-3: 2006	Electromagnetic compatibility Emission standard for residential, commercial and light industrial environments
IEC 61010-1: 2001	Safety requirements for electrical equipment for measurement, control and laboratory use. Part 1: General requirements

Place: Göttingen

Date: 12.02.2009

Legally binding signature:

issuer:

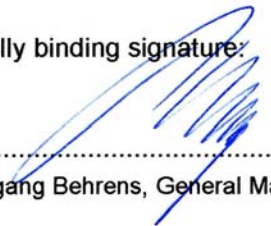
.....
Wolfgang Behrens, General Manager

.....
Joachim Beinhorn, Development Manager

This declaration certifies the compliance with the mentioned directives, however does not include any warranty of characteristics. Please pay attention to the security advises of the provided instructions for use.



ADOLF THIES GmbH & Co. KG

Hauptstraße 76 37083 Göttingen Germany
P.O. Box 3536 + 3541 37025 Göttingen
Phone +49 551 79001-0 Fax +49 551 79001-65
www.thiesclima.com info@thiesclima.com



- Alterations reserved-