

Operating Instructions

021566/01/08

Baro-Display LED

3.1156.0x.00x



ADOLF THIES GmbH & Co. KG

Hauptstraße 76 37083 Göttingen Germany
Box 3536 + 3541 37025 Göttingen
Phone +49 551 79001-0 Fax +49 551 79001-65
www.thiesclima.com info@thiesclima.com

Safety Instructions, Environment, Documentation

Operating Instructions

- © Copyright **Adolf Thies GmbH & Co KG**, Göttingen / Germany
- Although this document has been drawn up with due care, **Adolf Thies GmbH & Co KG** can accept no liability whatsoever for any technical and typographical errors or omissions in this document that might remain.
- We can accept no liability whatsoever for any losses arising from the information contained in this document.
- Subject to modification in terms of content.
- The device should not be passed on without the/these operating instructions.

Safety Instructions

- Read through the operating instructions before using the device for the first time.
- The device may only be fitted and connected by a qualified technician who is familiar with and observes the engineering regulations, provisions and standards applicable in each case.
- The device may only be fitted and connected when de-energised.
- **Adolf Thies GmbH & Co KG** guarantees proper functioning of the device provided that no modifications have been made to the mechanics, electronics or software and that the following points are observed.
- All information, warnings and instructions for use included in these operating instructions must be taken into account and observed as this is essential to ensure troublefree operation and a safe condition of the measuring system.
- The device is only designed for a specific application as described in these operating instructions.
- The device should only be operated with the accessories and consumables supplied and/or recommended by **Adolf Thies GmbH & Co KG**.
- Repairs may only be carried out by trained staff or **Adolf Thies GmbH & Co KG**. Only components and spare parts supplied and/or recommended by **Adolf Thies GmbH & Co KG** should be used for repairs.
- Opening the device may expose live parts possibly posing a lethal hazard if touched. It should only be opened for the purpose of repair by trained staff.
- When using the device, it must be ensured that it is not subjected to a service condition which might bring about damage to objects or present a risk to persons.
- All users must be constantly instructed about handling and safety of the device.
- Adjustment and maintenance performed while the opened device is energised may only be carried out by qualified technicians who are aware of the associated risk.
- The device may only be operated by trained technicians whose qualifications enable them to comply with the safety measures necessary during use of the device.
- In the event of any malfunction the device should no longer be used.
- The measuring results do not only depend on correct usage, installation and functioning of the device, but are also influenced by other factors. It is therefore necessary to check the results supplied by the measuring system for plausibility before taking action on the basis of such measuring results.

Environment

- As a longstanding manufacturer of sensors Adolf Thies GmbH & Co KG is committed to the objectives of environmental protection and is therefore willing to take back all supplied products governed by the provisions of "ElektroG" (German Electrical and Electronic Equipment Act) and to perform environmentally compatible disposal and recycling. We are prepared to take back all Thies products concerned free of charge if returned to Thies by our customers carriage-paid.
- Make sure you retain packaging for storage or transport of products. Should packaging however no longer be required, arrange for recycling as the packaging materials are designed to be recycled.



Contents

1	Device Versions	5
2	Application	5
3	Overview of Equipment and Functions	6
4	View	7
5	Mode of Operation	8
5.1	Acquisition of measured values.....	8
5.2	Calculation of sliding extreme values (Max/Min values).....	8
5.3	Trend of air pressure (P)	8
5.4	Altitude input for air pressure	9
5.5	Formula for calculation of altitude correction factor.....	9
5.6	Formula for calculation of QFF.....	10
5.7	Transition level TL.....	10
5.8	P-offset.....	11
6	Recommendation for Selection of Site.....	11
7	Installation.....	11
7.1	Mechanical installation	11
7.2	Electrical installation / connections.....	12
7.2.1	Connection: Serial interface RS422.....	12
7.2.2	Connection: Analog inputs (only for 3.1156.0x.xx1)	14
7.2.3	Connection: Analog output	14
7.2.4	Connection: Power supply	14
8	Data Output Protocol	15
9	Operation	16
10	Error Messages	24
11	Maintenance	24
12	Technical Data.....	25
13	Dimension Drawing	27
14	EC Declaration of Conformity	28

Figures

Fig. 1: Front 3.1156.0x.000	7
Fig. 2: Front 3.1156.0x.001	7
Fig. 3: Rear 3.1156.xx.xxx.....	12
Fig. 4: Termination	13
Fig. 5: Front view with operating buttons (Fig. 3.1156.0x.000)	16

Tables

Table 1: Device versions	5
Table 2: Table of operating functions	20
Table 3: Display status of MIN & MAX LEDs.....	21
Table 4: Device parameters	23
Table 5: Error messages	24

1 Device Versions

Designation	Order - No.	Equipment	Operating voltage
Baro-Display	3.1156.00.000	Input/output 1 x RS422 Output: 1 x 0.. 5/10 V or 0(4).. 20 mA	230 V AC; 24 V AC; 12...35 V DC
Baro-Display	3.1156.01.000	Input/output 1 x RS422 Output 1 x 0.. 5/10 V or 0(4).. 20 mA	115 V AC; 24 V AC; 12...35 V DC
Baro-Display	3.1156.00.001	Input/output 1 x RS422 Input 1 x Pt100 1 x 0.. 1/2/5/10 V or 0(4)..20 mA Output 1 x 0.. 5/10 V or 0(4).. 20 mA	230 V AC; 24 V AC; 15...35 V DC
Baro-Display	3.1156.01.001	Input/output 1 x RS422 Input 1 x Pt100 1 x 0.. 1/2/5/10 V or 0(4)..20 mA Output 1 x 0.. 5/10 V or 0(4)..20 mA	115 V AC; 24 V AC; 15...35 V DC

Table 1: Device versions

2 Application

The Baro-Display is a modern data-processing measuring and display device with an integrated barometric sensor. It offers a high level of reliability and flexibility as well as the optimum display of parameters.

Depending on the device version, parameters are shown in four lines on the display: 4 x barometric air pressure parameters (QNH, QFE, P, TL) or 2 x air pressure parameters (QFF, QFE), 1 x temperature and 1 x rel. humidity.

Red light-emitting diodes (LEDs), which are easily to read under a wide range of lighting conditions and distances, are used for display. Brightness is adjustable. Two brightness levels can be stored using an extended dimming function. This allows individual settings for daytime and night-time brightness to be called up quickly.

The Baro-Display is also used for serial and analog output of the measured data to further processing systems..

The device version **3.1156.00.xx1** has two analog inputs for the parameters of air temperature and rel. humidity. These two parameters provide for calculation and display of the parameter QFF.

Note:

With 3.1156.0x.001 it is essential to connect a hygro temperature sensor to calculate QFF.

3 Overview of Equipment and Functions

Designation	Baro-Display	Baro-Display	Baro-Display	Baro-Display
Article No.	3.1156.00.00 0	3.1156.01.000	3.1156.00.00 1	3.1156.01.001
Operating voltage				
230 V AC; 24 V AC; 12...35 V DC	X	----	X	----
115 V AC; 24 V AC; 12...35 V DC		X		X
Equipment				
1 x barometric sensor, built-in	X	X	X	X
4 x display	X	X	X	X
1 x serial interface (RS422)	X	X	X	X
1 x analog output (current or voltage)	X	X	X	X
1 x analog input (current or voltage)	----	----	X	X
1 x analog input (Pt100)	----	----	X	X
Measurement and calculation of:				
QNH as a function of the selected runway altitude above NHN*	X	X	----	----
QFE as a function of the selected station altitude	X	X	X	X
Air pressure (P) via the built-in pressure sensor	X	X	----	----
TL Transition level	X	X	----	----
QFF as a function of the selected runway altitude above NHN and the air humidity and air temperature prevailing at the station	----	----	X	X
Relative air humidity	----	----	X	X
Air temperature	----	----	X	X
Calculation and display of:				
QNH, QFE, TL transition level momentary value minimum value maximum value	X	X	----	----
Air pressure (P) momentary value 3h trend	X	X	----	----
QFF, QFE, rel. humidity, air temp. momentary value minimum value maximum value			X	X
Output of parameters displayed:				
Via serial interface RS 422	X	X	X	X
Output of prevailing air pressure (P):				
As value relating to current or voltage	X	X	X	X

*NHN: new abbreviation standardising height (altitude) levels through Germany according to the DHHN 92 system, i.e. "heights above Normalhöhennull (NHN, level datum of DHHN 92)".

4 View



Fig. 1: Front 3.1156.0x.000



Fig. 2: Front 3.1156.0x.001

5 Mode of Operation

5.1 Acquisition of measured values

The piezoceramic absolute pressure sensor integrated in the Baro-Display measures barometric air pressure and supplies the values necessary to calculate, display and output the various pressure parameters.

A sensor heating ensures that the pressure sensor functions with a high level of accuracy in a wide ambient temperature range.

5.2 Calculation of sliding extreme values (Max/Min values)

To process the sliding measured values, two ring buffers with a depth of 60 single values are available for each measured value. When measured values are processed every second, this results in a 1-minute sliding extreme value. If times > 1min are selected, the extreme value is calculated from the measured data record prior to sliding processing .

Sliding time	Extreme values from n minutes	Sliding extreme value from n values
1 min	1	60
10 min	10	60
1 h	60	60
24h	1440	60

The ring buffer is initialised whenever the Baro-Display is started up. The first valid measured value is written to the ring buffers so that a measured value appears in the display at once. A regular extreme value is then available after the time selected.

The times selected are not synchronised to clock time. They indicate the time period in the past.

Available intervals for the following parameters:

Parameter	Extreme value [t]							
QNH, QFE, TL, OFF, humidity, temperature.	1min	10min	30min	1h	2h	6h	12h	24h

5.3 Trend of air pressure (P)

Calculation of the air pressure trend is based on comparison between a 3 h sliding mean value of the air pressure (P) and the momentary air pressure (P). If the deviation between the momentary air pressure (P) and the 3h sliding mean value is > or < 1hPa, this is shown as a trend by illumination of the Min/Max LED in line 3 of the display.

Note: This function is only enabled in device version **3.1156.0x.000**.

5.4 Altitude input for air pressure

The following parameters can be corrected by inputting the altitude:

QFE	0-100m	Default = 0m	
QNH	0-3000m	Default = 0m	3.1156.0x.000
QFF	0-3000m	Default = 0m	3.1156.0x.001

Inputting of the altitude always relates to the station altitude (altitude of Baro-Display above NHN).

The buttons on the front of the device are used to input the altitude. See item 5 in section 10 for a description of how to input the altitude of the station.

5.5 Formula for calculation of altitude correction factor

QNH = p * factor (DIN ISO 2533)

p = hPa absolute air pressure (measured)

$$\text{Factor} = \left(1 - \frac{(a \cdot H \cdot r)}{(H+r) \cdot (T_o + t \cdot \text{NORM} + a \cdot H)} \right)^{5.2558797}$$

H = ???m

Station altitude above NHN

a

[K/m] temperature gradient

r

[m] Earth's radius

T_o

[K] 273.15 °C

tNORM

[°C] 15 °C standard temp. NHN

5.6 Formula for calculation of QFF

$$p = p_s \times e^{\left(\frac{g_n \times h}{R \times \left(t + T_0 + C \times e_d + \frac{gam \times h}{2} \right)} \right)}$$

$g_n = 9,80665 \text{ m/s}^2$ Acceleration of gravity
 $gam = 0,0065 \text{ K/gpm}$ Drop in temperature in K per geopotential metre
 $R = 287,05 \text{ J/kgK}$ Gas constant for dry air $R = R_0 / M$
 $M = 0,028965 \text{ kg/mol}$ Molar mass dry air
 $R_0 = 8,314510 \text{ J/molK}$ Gen. gas constant
 $T_0 = 273,15$ Conversion from °C to K
 $C = 0,11 \text{ K/hPa}$ DWD* coefficient to take account of air humidity
 t Momentary temperature at station in °C
 p_s Momentary air pressure at station in hPa (QFE)
 h Altitude of station in (geopotential) metres
 p Air pressure reduced to msl in hPa (QFF)
 e_d Momentary vapour pressure at station in hPa

$$e_d = f_{rel} \times E_0 \times e^{\left(\frac{17,5043 \times t}{241,2 + t} \right)}$$

$E_0 = 6,11213 \text{ hPa}$
 f_{rel} Relative air humidity (0-1.0)
 * German Meteorological Service

5.7 Transition level TL

Transition level refers to the altitude at which the altimeter setting is changed from standard air pressure to QNH, the air pressure actually prevailing, in a descending aircraft.

The transition level is classified according to the following criteria:

QNH [hPa]	978 or lower	979 – 1013	1014 – 1046	1047 or higher
Transition level [TL]	80	70	60	50

5.8 P-offset

P-offset is used to calibrate the Baro-Display.

The air pressure displayed can be corrected using the buttons on the front.

A correction value is calculated from the difference between the reference pressure input and the internally measured absolute pressure (P) and subsequently saved.

As the absolute pressure (P) is not displayed directly with model **3.1156.0x.xx1**, the QFE value has to be set to zero before calibration. The level for the QFE value should then be re-adjusted.

6 Recommendation for Selection of Site

The device is designed for indoor installation. When used outdoors, an additional external housing including the appropriate type of protection is required.

Note:

Pressure equalisation in relation to the atmospheric air pressure must be possible at the installation site of the Baro-Display.

Note:

When selecting the installation site, please take note of the operating temperature range.

7 Installation

Note:

The device should only be fitted and connected by qualified technicians. The general engineering regulations and provisions and standards applicable in each case must be observed.

7.1 Mechanical installation

The display is designed for installation in a control panel. The necessary opening in the control panel must measure 138 x 138 mm. The scope of supply includes two fixing brackets. After the device has been inserted in the control panel, the fixing brackets are slid into the housing at the rear and screwed into place.

7.2 Electrical installation / connections

All connections are at the rear

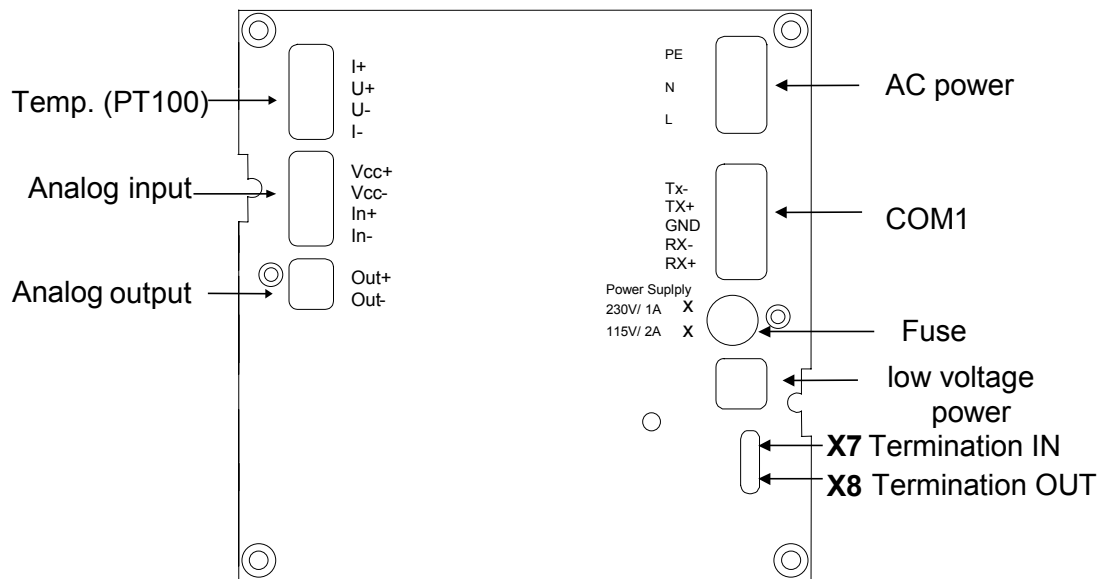

Fig. 3: Rear 3.1156.xx.xxx

7.2.1 Connection: Serial interface RS422

Desig.	Clamping plug: COM1
TX-	Transmitter
TX+	
GND	Ground
RX-	Receiver
RX+	

The following settings are possible:

Baud rates 1200, 2400, 4800, 9600, 19200, 57600

Interface specification 8N1, 7E1, 7O1

For termination with long cables the rear of the display has contact pins (X7), which can be bridged externally with a jumper if required (see Fig. 4).

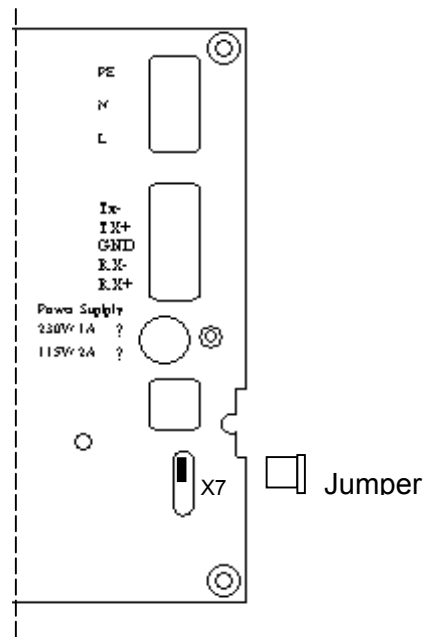

Fig. 4: Termination

Information for RS422:

Faults on long cables may affect serial transmission, with the serial interface possibly being destroyed by overvoltages. We therefore recommend:

- The transmission line should be shielded. The shield must be connected to a central ground potential.
- With cable connections longer than 100 m twisted pairs should be used for the signal lines +RX/-RX and +TX/-TX.
- The ground pins (GND) should be connected in addition to the twisted signal lines. If major differences in potential between the transmitter and receiver result in excessive compensating currents, isolating interface adapters must be used.
- The cable must always be terminated with its surge impedance (100 Ω to 600 Ω depending on the cable). With more than one Baro-Display LED (slaves) the resistor must be located at the receiver furthest from the transmitter.
- The integrated termination resistor ($R_T=200\Omega$) has to be activated using a jumper (X7) at the receiver (slaves) (see Fig. 2.).

7.2.2 Connection: Analog inputs (only for 3.1156.0x.xx1)

An analog input for current or voltage and a PT100 input.

- For external measured value transmitters with analog output for acquisition of temperature and rel. humidity:

Desig.	Clamping plug: Analog input (rel. humidity)
Vcc+	12V
Vcc-	Ground
In+	V, mA
In-	Ground

Desig.	Clamping plug: Temp (temperature)
+I	Pt100 in 4-wire circuit
+U	
-U	
-I	

7.2.3 Connection: Analog output

Analog output for absolute air pressure. Alternatively as current or voltage output.

Desig.	Clamping plug: Analog output (air pressure)
Out+	V, mA
Out-	V, mA

7.2.4 Connection: Power supply

- For Baro-Display 3.1156.00.000 / 001

Desig.	Clamping plug: AC power
PE	Protective conductor
N	230V AC
L	230V AC

or

Desig.	Clamping plug: low voltage power
1	24V AC/DC
2	24V AC/DC

- For Baro- Display 3.1156.01.000 / 001

Desig.	Clamping plug: AC power
PE	Protective conductor
N	115V AC
L	115V AC

or

Desig.	Clamping plug: low voltage power
1	24V AC/DC
2	24V AC/DC

8 Data Output Protocol

The output protocol contains all four display parameters. They are output in the display sequence 1 ... 4 and in the display format.

e.g. **3.1156.0x.001** protocol:

(STX)xxxx.x xxxx.x xx.x xxx.x*HL(CR)(ETX)

 | | | |
 QFF QFE rel. H Temp.

- ' ' (space) is used as a separator
- Erroneous parameters are replaced by "???."
- Missing parameters are replaced by "----."
- Measured values are output with leading ' ' (space) e.g. ' ' 0.1

e.g. **3.1156.0x.000** protocol:

(STX)xxxx.x xxxx.x xxxx.x xx.x*HL(CR)(ETX)

 | | | |
 QNH QFE P TL

Abbreviations:

' '	= blank character
"*"	= identifier for checksum
"H"	= checksum high
"L"	= checksum low
<STX>	= start of text
<ETX>	= end of text
<CR>	= carriage return
<LF>	= line feed

The checksum is created by the XOR function from the characters between <STX> and "*" 2...9 (starting with Hex00). The 8-bit checksum is then split into two ASCII characters (high and low nibble) with a value range from 0...F (Hex).

9 Operation

The Baro-Display is operated using the buttons on the front (s. Fig. 3). Whenever a button is pressed, this is acknowledged by an acoustic signal (bleep). The Baro-Display can be switched to 3 modes to display measured values and set parameters using the MODE button - see below for a description.



Fig. 5: Front view with operating buttons (Fig. 3.1156.0x.000)

Due to the restricted character representation in the 7-segment display the characters (texts) used in the select and input menus are listed here.

Select menu				
Menu No.	Display	Function	Menu items	Note
1	bAudr	Baud rate	1200, 2400, 4800, <u>9600</u> , 19200, 57600	<u>Default</u>
2	ProtF	Protocol format	<u>8n1</u> , 7E1, 7o1	<u>Default</u>
3	Et	Extreme value time	1n, 10n, 30n, 1h, 2h, 6h, 12h, <u>24h</u>	<u>Default (n = minute)</u>
5	tYP	Device type	000, 001	

Input menu	Display	Digits
Station altitude above runway	AltI	3
Station altitude above NHN	AltI	5
Reference pressure (P-offset)	PrEF	5

Menu structure:

The Baro-Display has 3 operating modes

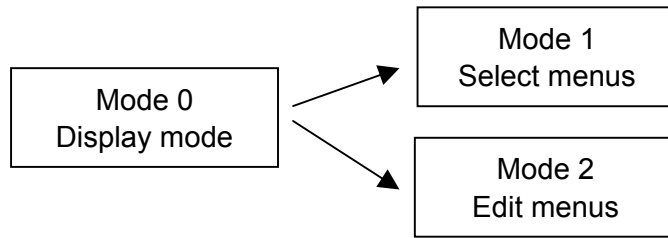

Mode 0 (display mode):

Whenever the device is restarted, the display automatically switches to operating mode 0 (Display measured values) and line 0. Line 0 is an imaginary line. The brightness level of the display lines can be selected in this mode.

The **"MODE" button** can be used to move to the next line. Indicated by the flashing MIN/MAX LEDs in each line.

The **"▲" (UP) button** and **"▼" (DOWN) button** can be used here to select display of the Mom, Min, Max values.

When the imaginary line 5 is reached, the display of measured values is switched off and the pressure sensor temperature is shown in lines 1 and 2 , e.g.

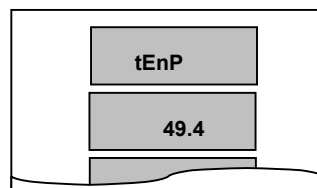

Overview of functions available in Mode 0

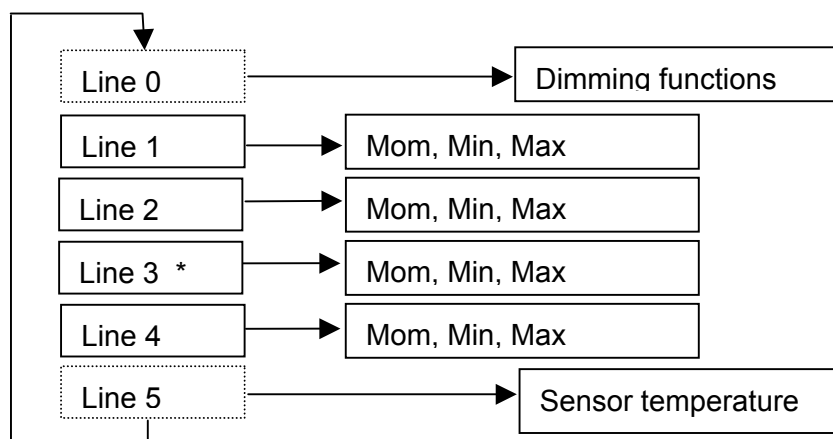

*Special function in line 3:

Device version **3.1156.0x.000**: Min/Max LED off = absolute air pressure
 Min/Max LED on = air pressure trend

Device version **3.1156.0x.001**: Min/Max LED off = momentary value rel. humidity
 Min/Max LED on = Min/Max rel. humidity

Mode 1 and Mode 2 (Programming mode):

Modes 1 and 2 are accessed by pressing the **"MODE"button** for over 3 sec.

Modes 1 and 2 differ from each other as follows:

Mode 1: Select menus of preset parameters

Mode 2: Editing of parameters

Every line can be assigned one or more select or input menus, which are accessed using the **"MODE" button**.

Global overview of menus available in Modes 1 and 2

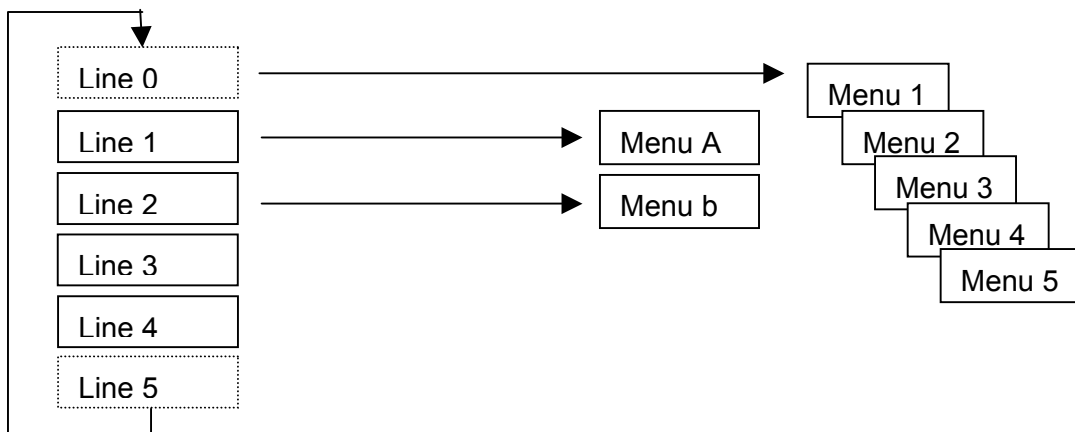

Select menus and edit menus which can be accessed via line 0

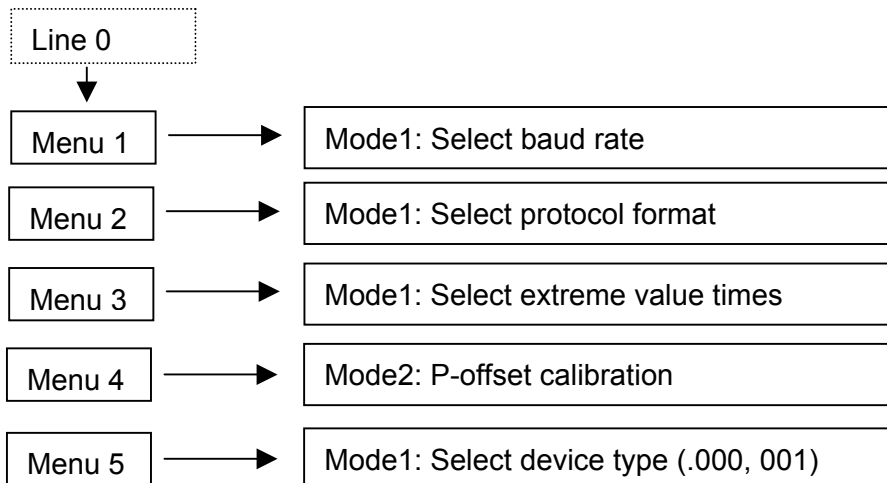

Input menus for lines 1 and 2

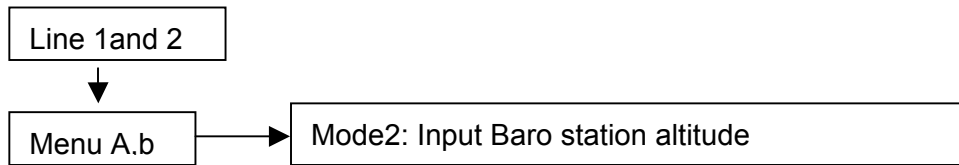

The select and edit menus are always shown in lines 1 and 2 of the display. Here the normal measured value display is switched off and the relevant menu appears.

e.g. Menu Select baud rate

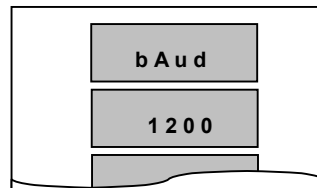

The possible operating functions are summarised in the following **Table of operating functions**. The MODE button is used to navigate through the 3 operator control levels (Mode 0-2). The areas marked in white in the table symbolise general operating functions of the display such as dimming, baud rate etc. The grey areas symbolise operating functions that specifically relate to a parameter.

Mod 0	Mod 1	Mod 2	Button	Function
x			▲▼	Dim display
x			▲ & ENTER	Save brightness value Max
x			▼ & ENTER	Save brightness value Min
x			▲ >3sec	Call up brightness value Max
x			▼ >3sec	Call up brightness value Max
x			MODE	Display line 1... 4 (Min/Max LED flashing)
x			▲▼	Select Mom/Min/Max (line n)
x			ENTER	Mom/Min/Max – Confirm selection (save) (line n)
x	→ x		MODE >3sec	Switch to Mode 1 Select menu 1 Baud rate COM1 (1)*
	x		MODE	Select menu 2 Protocol format COM1 (2)*
	x		MODE	Select menu 3 Times for sliding extreme values
	→ x		MODE	Edit menu 4 Input reference pressures (see below)
	x		MODE	Select menu 5 Device type (3)*
	x		▲▼	Select from menu list
x	← x		ENTER	Confirm selection (save)
x	← x		MODE >3sec	Return to Mode 0 without saving changes
x			MODE	Display line 1..4 (Min/Max LED flashing)
x	→ x		MODE >3sec	Switch to Edit mode Editing parameters 1 (line n)
		x	ENTER	Select editing parameters n (line n)
		x	MODE	Select a digit (flashing) in parameter n
		x	▲▼	Select digit or character (line n)
x	← x		ENTER	Save edited parameter n (line n)
x	← x		MODE >3sec	Return to Mode 0 without saving changes
x			Thies	Functional test, Info display and reset

Table 2: Table of operating functions

***Note re:**

- (1) Changes in select menu 1 and 2 (baud rate, protocol format) are only effective after restarting.
- (2) The protocol format setting only refers to data output.
- (3) This setting relates to the device configuraton and is preset (factory-set) and must not be changed.

Functions of MIN and MAX LEDs

The display status of the MIN and MAX LEDs is listed below as a function of mode:

Operating mode	LED MIN ▼	LED MAX ▲	Function / Status
Mode 0 (displays)	off	off	Display of momentary value
	on	off	Display of MIN value
	off	on	Display of MAX value
Mode 0 (programming)	flashing	flashing	Menu item Momentary value
	flashing	off	Menu item MIN value
	off	flashing	Menu item MAX value

Table 3: Display status of MIN & MAX LEDs

Examples of operation

1. Select brightness and save.

"▲" (UP) button Press repeatedly until required brightness level is reached.

"▲" (UP) button + "ENTER" button Hold down simultaneously until this operation is acknowledged by an "acoustic signal" (approx. 3sec). Brightness value is stored.

2. Call up stored brightness value.

"▲" (UP) button Hold down until this operation is acknowledged by an "acoustic signal" (approx. 3sec). The brightness level will change to the brightness value stored.

3. Select Max value display of parameter 3 in line 3.

"MODE" button Press repeatedly until Min/Max LEDs flash in line 3.

"▲" (UP) button Press repeatedly until Max LED flashes.

"ENTER" button Press. Max value display is selected.

4. Set time for generation of sliding extreme values to 1h.

"MODE" button Hold down until this operation is acknowledged by an "acoustic signal" (approx. 3sec). Select menu 1 (bAudr) appears in the display.

"MODE" button Press repeatedly until select menu 4 (Et) appears in the display.

"▲" (UP) button Press until 1h appears in the display.

"ENTER" button Press, and extreme value time will be stored.

5. Set Baro station altitude in line 1.

"MODE" button Press repeatedly until the MIN/MAX LEDs flash in line 1.

"MODE" button Hold down until this operation is acknowledged by an "acoustic signal" (approx. 3sec), and the station altitude appears in the input menu.

"ENTER" button Press. The first digit flashes and can now be changed using the **"▲" button** or **"▼" button**.

"MODE" button Press once and the second digit flashes. Adjust using the **"▲" button** or **"▼" button** etc.

"ENTER" button Press to accept value for altitude.

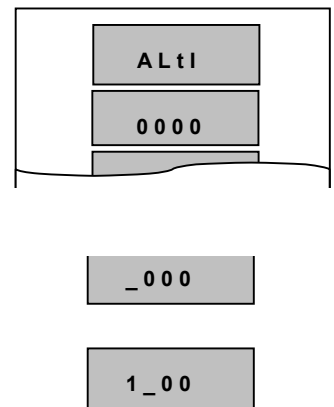

This button (**"INFO & RESET" button**):

Pressing the **"INFO & RESET" button** will start an LED test.

- All segments and LEDs light up
- All segments and LEDs off
- Display of device parameters (see **Table**)
- Restart of Baro-Display LED.

Device parameters

Device parameters	Display
Software	
Version No. (e.g.)	r 1.1
Device type	
3.1156.0x.000	t000
3.1156.0x.001	t001
Baud rate	
1200	b12
2400	b24
4800	b48
9600	b96
19200	b192
57600	b576
COM profile	
8n1	8n1
7e1	7E1
7o1	7o1
Sliding extreme value time	
1min	Et 1n
10min	Et10n
30min	Et30n
1h	Et 1h
2h	Et 2h
6h	Et 6h
12h	Et12h
24h	Et24h
Selected altitudes (m)	
Station altitude above NHN	Axxxx
Station altitude above runway	bxxx
P-offset (hPa)	Oxxx.x
Analogue IN Type	
0 – 1V	I0_1
0 – 2V	I0_2
0 – 5V	I0_5
0 – 10V	I0_10
0 – 20mA	I0_20
4 – 20mA	I4_20
Analogue OUT Type	
0 – 5V	o0_5
0 – 10V	o0_10
0 – 20mA	o0_20
4 - 20	o4_20

Table 4: Device parameters

10 Error Messages

If an error is detected during operation, an error code will be shown in the display for at least 3 seconds or as long as the error is present

Error code	Error	Comment/Action
E01	Internal Vcc 5V	Device defective: Send in.
E05	ADC error	AD converter defective.
E07	Parameter missing	QFE cannot be calculated. Parameter Temp./ rel. humidity missing.
E08	Measuring range exceeded	Measured value outside range for measured values.
E09	Timeout (COM)	No data telegram transmitted by barometric sensor.
E11	Protocol format	Format error in data telegram from barometric sensor.
E12	Check sum	Check sum error in data telegram from barometric sensor.
E13	MW missing	Character '!' or '?' instead of air pressure value from barometric sensor.
E14	MW missing	Character '-' instead of air pressure value from barometric sensor.
E99	Watchdog	Temporary malfunction if error message is shown once for 3sec. Repeated occurrence: source of interference nearby or device defective.

Table 5: Error messages

Another error message will be present if the pressure sensor temperature lies outside the error limits. In this case the display lines will flash with 2Hz.

11 Maintenance

The measuring results apply at the time of factory calibration. The user is responsible for repeating calibration and determining the time of performance.

Cleaning

To clean the face plate and housing, a dampened cloth should be used without chemical cleaning agents.

Storage

The device must be stored in a dry room free of dust at temperatures between -20. + 50°C. We recommend storing the device in a cardboard box.

Fuse

There is a mains fuse at the rear of the device. The fuse holder can be opened using a screwdriver.

Caution:

***In the event of a defect only the following fuses should be used:
230V ; 0.25 A slow for Baro-Display 3.1156.00.00x
115V ; 0.5 A slow for Baro-Display 3.1156.01.00x***

12 Technical Data

Display	Type	LED, red, 7-segment			
	Display	4 x 5-digit LED, height 14mm 4 x Min/Max LED – arrow			
	Display range	- 9.999 ... + 99999			
Pressure sensor					
Barometr. air pressure	Measuring range	600 ... 1100 hPa			
	Resolution	0.01 hPa			
	Accuracy	± 0.25 hPa			
Pressure sensor heating	Contol temperature	50°C ±1°K			
Interfaces					
1 x serial interface					
	Type	RS422			
Data format	Output	7E1, 8N1, 7O1			
	Input	7E1, 8N1, 7O1			
	Baud rate	1200, 2400, 4800, 9600, 19200, 57600			
1 x analog output					
Absolute air pressure (P)	Range	600 ...1100hPa			
Voltage	Output	0 ... 5V			
	Output	0 ... 10V			
	Accuracy	±0.3% of meas. range @T _{amb} +20°C			
	R(load)	>50kΩ (output 0.. 10V), > 1kΩ (output 0... 5V)			
or					
Current	Output	0(4)... 20 mA			
	Accuracy	±0.3% of MBE @ T _{amb} +20°C			
	R _L (load impedance)	≤ 350Ω @ U _B ≥ 15V DC			
Analog inputs	only with version	3.1156.0x.001			
1 x voltage	Input	0 ... 1V	0 ... 2V	0 ... 5V	0 ... 10V
	Resolution	0.001V	0.001V	0.0012V	0.0025V
	Accuracy	±0.5%	±0.3%	±0.2%	±0.2%
or					
1 x current	Input	0 ... 20 mA	4 ... 20 mA		
	Resolution	0.01 mA	0.01 mA		
	Accuracy	±0.3%	±0.3%		
1 x temperature	Input	Pt 100, four-wire circuit (- 40... 70°C)			
	Resolution	0.005°C			
	Accuracy	± 0.1°C			

Power supply external sensors	<i>only with version</i>	3.1156.0x.001
1 x voltage U (Vcc)	Output	12V
	Icc (max)	50 mA
	Fuse	Polyswitch approx. 100 mA
Altitude input	Station altitude above NHN	Altitude range 0... 3000m
	Station altitude above runway	Altitude range 0... 100m
Display	Momentary value	
	Extreme value time (Max/Min value)	1min, 10min, 30min, 1h, 2h, 6h, 12h, <u>24h</u>
Trend display	<i>only with version</i>	3.1156.0x.000
	Reference pressure	3h sliding mean value
	Hysteresis	± 0.9 hPa
Electricity supply	Mains	230VAC (with 3.1156.00.00x)
	Mains	115VAC (with 3.1156.01.00x)
	Mains fuse	0.25 A slow or 0.52 A slow
	Low voltage U_B	18...28 VAC or 12(15)...35 VDC
	Power consumption	Max. 1000mA at 12VDC
Ambient conditions	Temperature range	T _{amb} -10... +50 °C
	Humidity range	Non-condensing
Housing	Material	Aluminium
	Dimensions	144 x 144 mm Depth: 119 mm
	Weight	1.5 kg
	Type of protection	IP20; EN 60529

13 Dimension Drawing

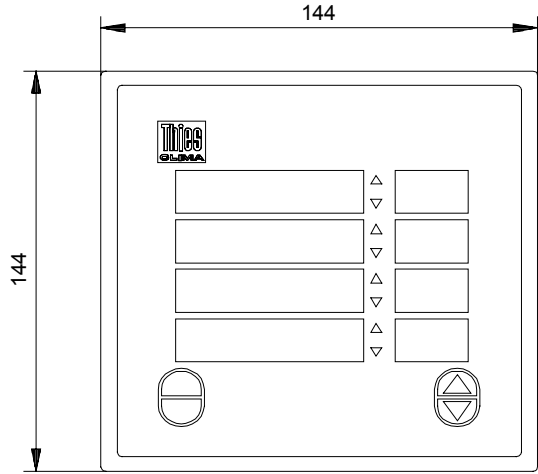

Control panel openig
 As per DIN 43700
 $138^{+1} \times 138^{+1}$

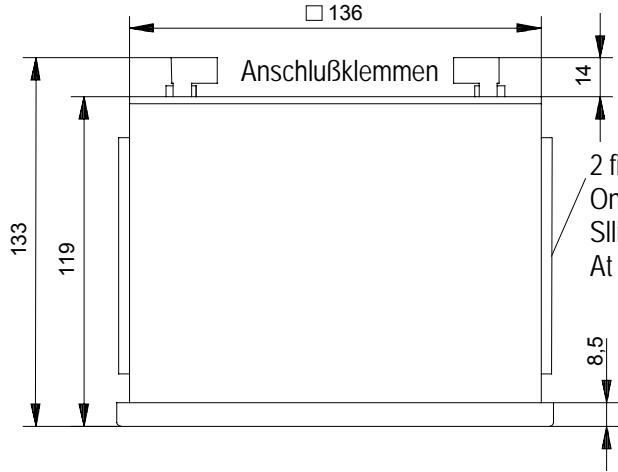

2 fixing brackets
 On right and left
 Slid into housing / rear panel
 At rear and screwed into place

14 EC Declaration of Conformity

Document-No.: **002004**

Month: 10 Year: 08

Manufacturer: **ADOLF THIES GmbH & Co. KG**

Hauptstr. 76
D-37083 Göttingen
Tel.: (0551) 79001-0
Fax: (0551) 79001-65
email: Info@ThiesClima.com

Description of Product: **Baro Display LED**

Article No. **3.1156.00.000** **3.1156.00.001** **3.1156.01.000** **3.1156.01.001**

specified technical data in the document: **021565/01/08**

The indicated products correspond to the essential requirement of the following European Directives and Regulations:

- | | |
|-------------|--|
| 2004/108/EC | DIRECTIVE 2004/108/EC OF THE EUROPEAN PARLIAMENT AND OF THE COUNCIL of 15 December 2004 on the approximation of the laws of the Member States relating to electromagnetic compatibility and repealing Directive 89/336/EEC |
| 2006/95/EC | DIRECTIVE 2006/95/EC OF THE EUROPEAN PARLIAMENT AND OF THE COUNCIL of 12 December 2006 on the harmonisation of the laws of Member States relating to electrical equipment designed for use within certain voltage limits |
| 552/2004/EC | Regulation (EC) No 552/2004 of the European Parliament and the Council of 10 March 2004 on the interoperability of the European Air Traffic Management network (the interoperability Regulation) |

The indicated products comply with the regulations of the directives. This is proved by the compliance with the following standards:

Reference number	Specification
IEC 61000-6-2: 2005	Electromagnetic compatibility Immunity for industrial environment
IEC 61000-6-3: 2006	Electromagnetic compatibility Emission standard for residential, commercial and light industrial environments
IEC 61010-1: 2001	Safety requirements for electrical equipment for measurement, control and laboratory use. Part 1: General requirements

Place: Göttingen

Date: 22.10.2008

Legally binding signature:

issuer:

.....
Wolfgang Behrens, General Manager

.....
Joachim Beinhorn, Development Manager

This declaration certifies the compliance with the mentioned directives, however does not include any warranty of characteristics. Please pay attention to the security advises of the provided instructions for use.



ADOLF THIES GmbH & Co. KG

Hauptstraße 76 37083 Göttingen Germany
P.O. Box 3536 + 3541 37025 Göttingen
Phone +49 551 79001-0 Fax +49 551 79001-65
www.thiesclima.com info@thiesclima.com



- Alterations reserved-