

Instruction for use

020727/08/13

Hygro-ThermoTransmitter-compact

1.1005.54.780 / 781/ 782

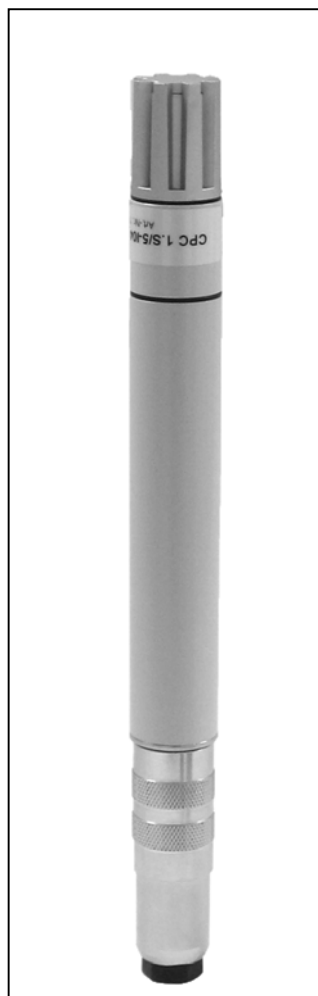

ADOLF THIES GmbH & Co. KG

Hauptstraße 76 37083 Göttingen Germany
Box 3536 + 3541 37025 Göttingen
Phone +49 551 79001-0 Fax +49 551 79001-65
www.thiesclima.com info@thiesclima.com

Safety Instructions

- Before operating with or at the device/product, read through the operating instructions. This manual contains instructions which should be followed on mounting, start-up, and operation. A non-observance might cause:
 - failure of important functions
 - Endangering of persons by electrical or mechanical effect
 - Damage to objects
- Mounting, electrical connection and wiring of the device/product must be carried out only by a qualified technician who is familiar with and observes the engineering regulations, provisions and standards applicable in each case.
- Repairs and maintenance may only be carried out by trained staff or **Adolf Thies GmbH & Co. KG**. Only components and spare parts supplied and/or recommended by **Adolf Thies GmbH & Co. KG** should be used for repairs.
- Electrical devices/products must be mounted and wired only in voltage-free state.
- **Adolf Thies GmbH & Co KG** guarantees proper functioning of the device/products provided that no modifications have been made to the mechanics, electronics or software, and that the following points are observed:
- All information, warnings and instructions for use included in these operating instructions must be taken into account and observed as this is essential to ensure trouble-free operation and a safe condition of the measuring system / device / product.
- The device / product is designed for a specific application as described in these operating instructions.
- The device / product should be operated with the accessories and consumables supplied and/or recommended by **Adolf Thies GmbH & Co KG** .
- Recommendation: As it is possible that each measuring system / device / product under certain conditions, and in rare cases, may also output erroneous measuring values, it is recommended using redundant systems with plausibility checks with **security-relevant applications**.

Environment

- As a longstanding manufacturer of sensors Adolf Thies GmbH & Co KG is committed to the objectives of environmental protection and is therefore willing to take back all supplied products governed by the provisions of "*ElektroG*" (German Electrical and Electronic Equipment Act) and to perform environmentally compatible disposal and recycling. We are prepared to take back all Thies products concerned free of charge if returned to Thies by our customers carriage-paid.
- Make sure you retain packaging for storage or transport of products. Should packaging however no longer be required, arrange for recycling as the packaging materials are designed to be recycled.



Documentation

- © Copyright **Adolf Thies GmbH & Co KG**, Göttingen / Germany
- Although this operating instruction has been drawn up with due care, **Adolf Thies GmbH & Co KG** can accept no liability whatsoever for any technical and typographical errors or omissions in this document that might remain.
- We can accept no liability whatsoever for any losses arising from the information contained in this document.
- Subject to modification in terms of content.
- The device / product should not be passed on without the/these operating instructions.

Contents

1	Models available	3
2	Application	4
3	Mounting	4
4	Connection.....	5
4.1	Connector Pin Assignment.....	5
4.2	Cable Assignment	5
5	Maintenance	5
6	Notes on sensors with MODBUS-RTU	6
6.1	Serial format and transfer rate.....	6
6.2	Overview of available MODBUS registers.....	6
6.3	Configuration of MODBUS address	7
6.4	Reading the measured values.....	7
6.5	Use of internal termination.....	8
7	Address programming methods	8
7.1	In the test network.....	8
7.2	In the operating network (remotely controlled)	9
8	Technical Data.....	10
9	Accessories / spare part (optional)	11
10	EC-Declaration of Conformity.....	12

1 Models available

Order-No.	Measuring Range	Electrical Output	Operating Voltage	Sensor protective filter	Construction / Connection
1.1005.54.780	0...100% r. F. -40... +85°C	RS 485 MODBUS RTU	5...30V DC	ZE20	- H-T-Transmitter with plug and mating plug
1.1005.54.780	0...100% r. F. -40... +85°C	RS 485 MODBUS RTU	5...30V DC	ZE20	- H-T-Transmitter plug connection - mating plug with 5 m cable and wire end
1.1005.54.780	0...100% r. F. -40... +85°C	RS 485 MODBUS RTU	5...30V DC	ZE20	- H-T- Transmitter plug connection - mating plug with 10 m cable and wire end

This hygro-thermo transmitter has a digital RS 485 output, and is suited for the data transmission acc. to MODBUS RTU protocol.

2 Application

The Hygro-Thermo Transmitters of our compact series are designed to measure relative humidity, the temperature of the air and other non-aggressive gases.

The use of capacitive humidity sensors is a guarantee for:

- a high degree of long-term stability
- nearly linear characteristics
- good dynamic behaviour
- dewing stability
- low temperature coefficients
- low hysteresis

The hygro-thermo transmitter is equipped with a protective filter for the sensors.

Type: Membrane-filter with gauze ZE20 (order-no. 1.1005.54.901) for protection against dust in case of field application.

Remark:

For field work, it is advisable to use a „Weather and Thermal Radiation Shield“. It is optionally available as accessory.

3 Mounting

For correct measurements, the Hygro-Thermo Transmitter should be mounted at a site in the room which is representative of the climate within the room. The mounting position itself is arbitrary. Mount the sensor such that water cannot penetrate the inside of the sensor. Dewing and sprinkling water do not damage the sensor.

Moreover, please make sure to keep the operating voltages as well as a good recirculation ventilation of the instrument. Deviations might lead to measurement errors (for example: due to instrument warming).

Preferably, the sensor should be mounted vertically facing downwards to a wall (indoor application), and should be mounted horizontally facing backwards in canals.

4 Connection

4.1 Connector Pin Assignment

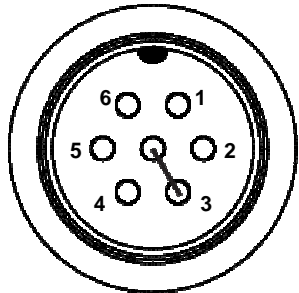
Pin	Description	Function	Position of connections at the sensor
1	reserved		
2	D0/A/Data+	MODBUS RS485 Data+	
3	D1/B/Data-	MODBUS RS485 Data-	
4	Vcc	Supply voltage +	
5	GND	Supply voltage 0V	
6	reserved		
7	Termination	Termination active, when Pin 3 and Pin 7 connected	

4.2 Cable Assignment

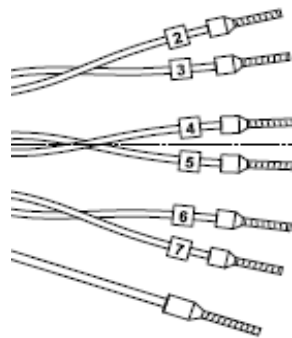
Code ring	Lead color	Description	Function	Lead color marking
2	Brown	D0/A/Data+	MODBUS RS485 Data+	
3	Black	D1/B/Data-	MODBUS RS485 Data-	
4	Red	Vcc	Supply voltage +	
5	Black	GND	Supply voltage 0V	
6	Orange	D0/A/Data+	MODBUS RS485 Data+	
7	Black	D1/B/Data-	MODBUS RS485 Data-	
--	Green/yellow	shield		

5 Maintenance

The Hygro-Thermo Transmitter is supplied already adjusted and its characteristics remain stable for years.

Dust does not damage the humidity sensor but does influence the dynamic behaviour negatively. If the instrument is very dirty, the sensor element can be cleaned or carefully rinsed in distilled water. Make sure you do not touch the highly-sensitive sensor element.

Before cleaning the sensor elements please remove the protecting filter; it should be cleaned, as well or should be replaced.

Attention:

The instrument housing with the electronics included should be opened only in the factory.

6 Notes on sensors with MODBUS-RTU

6.1 Serial format and transfer rate

The following parameters are applicable for data transfer via the RS-485 interface on the MODBUS sensors:

half-duplex with twin wires

19200 bit per second

8 data bit

no parity testing

1 stop bit

monitoring interval (recommended) > 1s

a maximum of 8 registers per query

6.2 Overview of available MODBUS registers

All registers can be read using the MODBUS function code "03" (Read Holding Register) or the MODBUS function code "04" (Read Input Register). Table 1 shows all available registers for MODBUS sensors:

16 bit register-no.	format	value	
0000-0001	float (32bit)	temperature in °C	read-only
0002	int (16bit)	alarm code temperature	
0003-0004	float (32bit)	humidity in % r.h.	
0005	int (16bit)	alarm code humidity	
0006 - 0007	long (32bit)	serial number sensor	
0205	int (16bit)	MODBUS address	read and writeable

Table 1: MODBUS Register

Alarmcode:

Temperature channel:	Humidity channel:
0 = no alarm, the temperature value is within the limits	0 = no alarm, the humidity value is within the limits
1 = temperature measurement range exceeded	1 = humidity meas. range exceeded (=100% r.h.)
2 = below temperature measurement range	2 = below humidity meas. range (= 0% r.h.)
3 = no sensor signal	3 = no sensor signal
4 = short circuit at PT1000 (resistance < 500 Ω)	4 = humidity sensor defective

Table 2: alarm codes humidity and temperature

6.3 Configuration of MODBUS address

Every sensor has its own MODBUS address which can be changed through the MODBUS protocol. With write access to the register „0205“ (see table 1), you can change the MODBUS address of the respective sensor.

The write command to the address register of the respective sensor presumes a valid target address in the MODBUS network. Please make sure at this point that the newly assigned MODBUS address is not already taken. If the current target address of the sensor is unknown, the MODBUS sensors can always be activated using the MODBUS address 255.

For this reason, the address 255 is excluded from the regular address-allocation in the network with the application of these sensors. With address 255 all sensors of this type are activated at the same time.

The only exception to this rule is when you are operating a single sensor per network segment, for example during maintenance via the service interface, starting up a test network or as a permanent single sensor solution. In figure 1 the structure of a MODBUS frame is given with the write command to change the MODBUS address:

MODBUS address	Function code	Register address	Argument (new MODBUS address)	CRC Check-sum
8 bit	8 bit	16 bit	16 bit	16 bit
e.g. 255	6	205	1-254 (255 reserved)	CRC Check-sum

Figure 1: Allocation of a new MODBUS address

6.4 Reading the measured values

The registers of the MODBUS sensors can be read using the MODBUS function code “03“ (Read Holding Register) or the MODBUS function code “04“ (Read Input Register). The range for the register to be read can be specified in the argument of both function codes. All registers between the start and stop address of the argument, including the registers with both addresses themselves, are read. This means that all measured values with their alarm registers and the serial number (address range 0000 to 0007) are read through information retrieval. If the start and stop address are identical, then only one register with the corresponding address is read.

In the following example, the first two MODBUS registers (0000-0001) are read which together represent the measured value for the temperature in Float32 format. The MODBUS address of the sensor has been set arbitrarily at 119.

MODBUS address	Function code	Start address register	Stop address register	CRC Checksum
8 bit	8 bit	16 bit	16 bit	16 bit
119	3	00 00	00 01	CRC Checksumme

Figure 2: Reading the measured values

6.5 Use of internal termination

The MODBUS sensors have internal DC termination with a resistance value of 135 Ohm. With the sensors the termination can be activated by bridging Pin 3 and Pin 7 in the threaded bush of the connecting cable.

Termination is recommended for the following applications:

- Single sensor operation with medium to long cable lengths or
- Operating the network with several sensors using the following parameters
 - Pull resistances on cables D0 and D1 greater than 750 Ohm (in the master)
 - Number of sensors in the network segment smaller than 10 with poll intervals > 1s in total network.

To guarantee the accuracy of the measured values, the internal DC termination of sensors is not recommended for other applications. In this case, the termination resistance needs to be spatially separated due to heat build-up.

Note:

The interrogation frequency of all sensors in the network is relevant to termination resistance heat build-up. For short cable lengths (up to 20m), termination can be dispensed with.

7 Address programming methods

7.1 In the test network

- Recommended during incoming goods inspection
- requires PC with RS-485 interface and MODBUS master software (e.g.: MODBUS Poll) or a MODBUS master system.

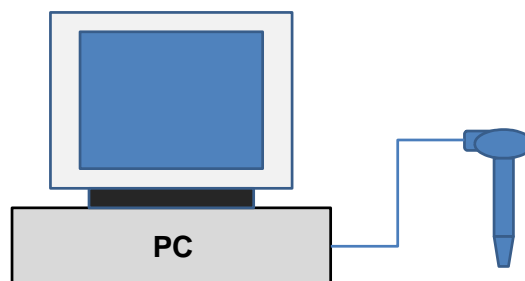

7.2 In the operating network (remotely controlled)

- In the case of retrospective changes to the operating network
- Assignment of address through the MODBUS master used by sending a „write“ command to the address register 205 in the sensor (refer to section „Configuration of MODBUS address“)

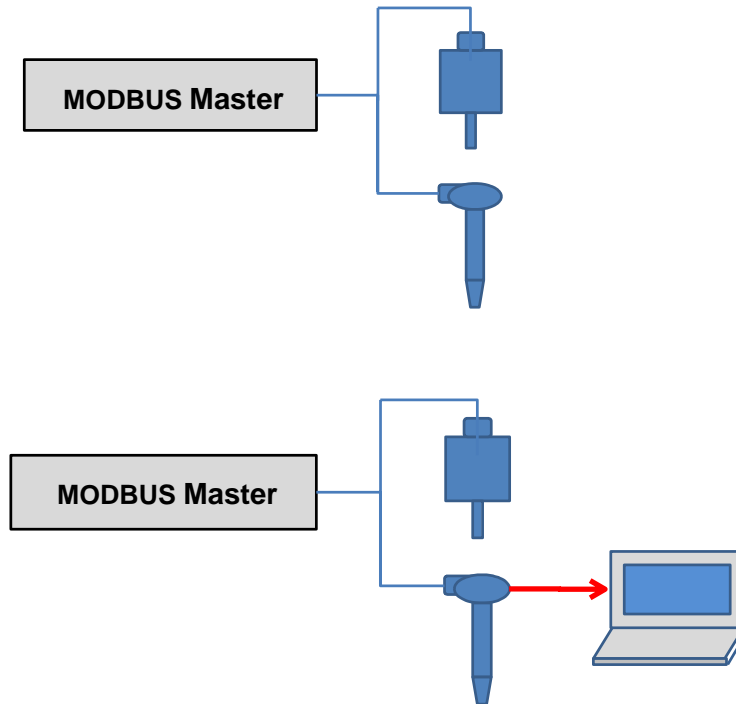

8 Technical Data

Humidity	
Measuring element	Capacitive
Measuring range	0...100 % rel. humidity
Accuracy @ meas. range 10...90% rel.F. bei 23 °C @ meas. range <10% rel.F. >90% rel.F.	± 1,5 % rel. humidity ± 2 % rel. humidity
Response Time (T 90)	<20 s (at v = 1,5 m/s) w/o filter
Response Time (T 90)	<1,5 min. (at v = 1,5 m/s) with Membrane filter ZE 20
Response Time (T 90)	<1,5 min. (at v = 1,5 m/s) with Sinter filter ZE 21
Temperature	
Measuring element	Pt 1000 Class B, 1/3 DIN tolerance
Measuring range	-40...+85°C
Accuracy @ 23°C	± 0,2 K
Response time (T 90)	<20 s (at v = 1,5 m/s) w/o filter
Response time (T 90)	<1,5 min. (at v = 1,5 m/s) with Membrane filter ZE 20
Response time (T 90)	<1,5 min. (at v = 1,5 m/s) with Sinter filter ZE 21
Additional Specifications	
Ambient temperature	-40...+85°C
Degree of protection sensor	IP 30
Degree of protection sensor with filter	IP 54
Degree of protection electronics	IP 67
Operating voltage	5...30 V DC
Current requirement	Approx. < 5 mA
Dimension to model 1.1005.54.780	
Diameter	20 mm
Length w/o plug	126 mm
Length with plug	Approx. 145 mm

9 Accessories / spare part (optional)

<p>Weather and Thermal Radiation Shield</p> <p>The use of the Weather and Thermal Radiation Shield in an appropriate combination with suitable temperature and humidity sensors reduces to a minimum the possibility of influencing the data in a negative manner by radiation, precipitation or damage.</p> <p>More exactly measuring results are achieved by using the ventilated Weather and Thermal Radiation Shield (mod. 1.1025.55.10x with ventilation). The ventilation reduces those errors which might occur during the measurements in a weather hut caused by the so-called „proper climate“.</p>	<p>1.1025.55.00x .10x .xx0 .xx1</p>	<p>w/o ventilator with ventilator 12 V DC / 2 W , incl. 5 m cable for mast tube mounting \varnothing 30 - 50 mm for mast tube mounting \varnothing 55 – 60 mm</p> <p>dimensions: \varnothing 120 x 290 mm</p>
<p>Membrane-filter with gauze ZE20</p> <p>The filter serves for protecting the sensor elements of the Hygro-thermo transmitter against dust in case of field application.</p>	<p>1.1005.54.901</p>	<p>Material: PTFE / stainless steel Dimensions: \varnothing 20 x 25 mm</p>

10 EC-Declaration of Conformity

Document-No.: **000702**

Month: 08 Year: 13

Manufacturer: **ADOLF THIES GmbH & Co. KG**

Hauptstr. 76
D-37083 Göttingen
Tel.: (0551) 79001-0
Fax: (0551) 79001-65
email: Info@ThiesClima.com

Description of Product: **Hygro – Thermo Transmitter Compact**

Article No.	1.1005.49.960	1.1005.51.600		
1.1005.54.000	1.1005.54.150	1.1005.54.160	1.1005.54.161	1.1005.54.173
1.1005.54.241	1.1005.54.300	1.1005.54.441	1.1005.54.448	1.1005.54.460
1.1005.54.461	1.1005.54.700	1.1005.54.701	1.1005.54.703	1.1005.54.741
1.1005.54.761	1.1005.54.773	1.1005.54.780	1.1005.54.781	1.1005.54.782
1.1005.54.800	1.1005.54.941	1.1005.54.961	1.1005.64.000	1.1005.64.161
1.1005.64.701	1.1005.64.241			

specified technical data in the document:

**020874/06/13; 021659/04/11; 021660/04/11; 021661/04/11
021687/01/12; 021691/01/12; 020726/08/13**

The indicated products correspond to the essential requirement of the following European Directives and Regulations:

2004/108/EC	DIRECTIVE 2004/108/EC OF THE EUROPEAN PARLIAMENT AND OF THE COUNCIL of 15 December 2004 on the approximation of the laws of the Member States relating to electromagnetic compatibility and repealing Directive 89/336/EEC
2006/95/EC	DIRECTIVE 2006/95/EC OF THE EUROPEAN PARLIAMENT AND OF THE COUNCIL of 12 December 2006 on the harmonisation of the laws of Member States relating to electrical equipment designed for use within certain voltage limits
552/2004/EC	Regulation (EC) No 552/2004 of the European Parliament and the Council of 10 March 2004 on the interoperability of the European Air Traffic Management network (the interoperability Regulation)

The indicated products comply with the regulations of the directives. This is proved by the compliance with the following standards:

Reference number	Specification
IEC 61000-6-2: 2005	Electromagnetic compatibility Immunity for industrial environment
IEC 61000-6-3: 2006	Electromagnetic compatibility Emission standard for residential, commercial and light industrial environments
IEC 61010-1: 2010	Safety requirements for electrical equipment for measurement, control, and laboratory use. Part 1: General requirements

Place: Göttingen

Date: 13.08.2013

Legally binding signature:

issuer:

.....
Wolfgang Behrens, General Manager

.....
Joachim Beinhorn, Development Manager

This declaration certifies the compliance with the mentioned directives, however does not include any warranty of characteristics. Please pay attention to the security advises of the provided instructions for use.



ADOLF THIES GmbH & Co. KG

Hauptstraße 76 37083 Göttingen Germany
P.O. Box 3536 + 3541 37025 Göttingen
Phone +49 551 79001-0 Fax +49 551 79001-65
www.thiesclima.com info@thiesclima.com



- Alterations reserved-